



VIEWBOARD

ViewBoard IFP6550-3

Key Features

- Intuitive Interactive Interface and Eye-care Certified Display
- Synchronous Writing Performance with Dual Pens
- Lag-free, Pen-on-paper Writing Experience with Ultra Fine Touch Technology
- Native Whiteboarding Tool with built-in myViewBoard® App
- Wireless Content Sharing and 4-way Split Screen with ViewBoard® Cast App



Product Description

For teachers in the modern classroom, the ViewBoard® IFP50 series has the most intuitive interactive interface. It keeps continuous interaction within the first vision area and keeps everything within comfortable reach. Additionally, it is an eye-care certified display with low blue light and flicker-free at all brightness levels. The ViewBoard® IFP50 series further stands out with synchronous writing performance. You can write smoothly, with the pen that serves as an extension of your fingertips, and simultaneously with the equipped dual pens of different colours and thicknesses. The native built-in whiteboarding tool, myViewBoard®, further helps visualise your ideas with ease. The ViewBoard® IFP50 series is further complimented by wireless content sharing. Students can share their screens to the ViewBoard and vice versa with the built-in ViewBoard® Cast app. It is not limited to one-on-one presentation either. Teachers can advance to do group activities with the 4-way split screen display. Whether you've experienced good or lackluster classroom interaction in the digital whiteboarding world, the ViewBoard® IFP50 series will now allow you to work effortlessly in the classroom.

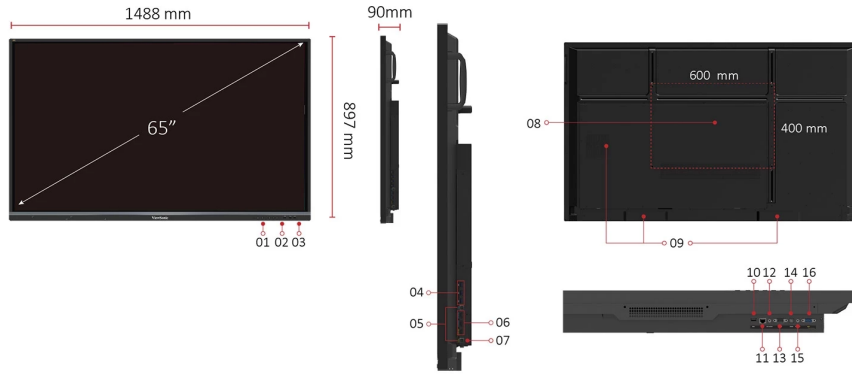

- 1. MENU CONTROLS
- 2. USB 3.0
- 3. USB 2.0
- 4. USB 3.0
- 5. TOUCH
- 6. HDMI IN X 3
- 7. Wi-Fi Module Slot

- 8. VESA® Wall Mount 600x400mm
- 9. INTERNAL SPEAKERS
- 10. USB 2.0
- 11. LAN
- 12. Audio Out
- 13. RS232
- 14. SPDIF

- 15. Audio In
- 16. VGA

Visit Us

www.viewsonic.com

DISPLAY

Panel Size:	65"
Type/Tech:	TFT LCD Module with DLED Backlight.
Display Area (mm):	1431 (H) x 807 (V) (64.5" diagonal)
Aspect Ratio:	16:9
Native Resolution:	UHD 3840x2160 (Pixels)
Colors:	1.07B colors (10bit)
Brightness:	350 nits (typ.)
Contrast Ratio:	5000:1 (DCR)
Response Time:	8ms
Viewing Angles:	H = 178, V = 178 typ.
Backlight Life:	50,000 hrs
Surface Treatment:	Hardness: 9H, Anti-flare coating
Bezel:	Slim
Orientation:	Landscape

PLATFORM

Processor:	ARM Cortex-A73*2 + Cortex-A53*2 1.5GHz
RAM:	3GB DDR4
Storage:	32GB

TOUCH

Type/ Tech:	IR Recognition
Touch Resolution:	32767 x 32767
Touch Point:	20 points touch, 10 points writing

INPUT

HDMI:	2.0 x3 (3840x2160 @60Hz)
RGB / VGA:	x1
Audio:	x1 (PC audio in)
RS232:	x1
OPS:	x1 PC Slot (proprietary)

OUTPUT

Audio:	x1 (Earphone out)
SPDIF:	1 (optical)

LAN

RJ45:	x1
-------	----

USB

Type A:	USB2.0: Front x2, Rear x1 (SmartPort™ for all), USB3.0: Front x1, Rear x3 (SmartPort™ for Rear x3)
Type B:	x2, for touch

SPEAKERS

10W x 2 + 15W x 1

TOP CAMERA PLATE

Yes

COMPATIBILITY

HDMI:	3840x2160
-------	-----------

EMBEDDED OS

Android 8

BUNDLE SOFTWARE

Basic Annotation Software:	myViewBoard
Pro Annotation Software:	myViewBoard for Windows (Embedded in Windows Slot-in PC)

SPECIAL FEATURES

All-in-one USB port (combine Windows/Android USB port; no need to distinguish them anymore):	Front "SmartPort™ USB" to all channels.
Simple LAN sharing between IFP and slot-in device:	10M/100M/ for Android, 10M/100M/1000M for slot-in PC

POWER

Voltage:	100-240VAC +/- 10% Wide Range
Consumption:	On: 108W(typ.) / Off: <0.5W

ERGONOMICS

Wall Mount (VESA®):	600 x 400
----------------------	-----------

OPERATING CONDITIONS

Temperature (° C):	0°C to 40°C
Humidity:	10% ~ 90% RH non-condensing

DIMENSIONS (W X H X D)

Physical (inch / mm):	58.6 x 35.3 x 3.5 in / 1488 x 897 x 90 mm
Packaging (inch / mm):	65.7 x 39.8 x 8.8 in / 1669 x 1010 x 223 mm

WEIGHT

Net (lb / kg):	89.3 lb / 40.5 kg
Gross (lb / kg):	109.6 lb / 49.7 kg

REGULATIONS

cTUVus, FCC, ES8, EPEAT, EMC/CE, CB, RoHS & DOC, REACH, WEEE, ErP, EAC, UKrSEPRO, RCM, BSMI

PACKAGE CONTENTS

1. Power cable (3 meters). x2
2. Remote control
3. USB cable (3 meters)
4. Touching pen x2
5. Quick Start Guide
6. RS232 adapter
7. Clamp x5
8. Plate
9. Screw x8
10. HDMI cable 3M

COMPATIBLE SLOT-IN PC

VPC14-WP series, VPC10-WP series, VPC15-WP series, VPC16-WP series, VPC17-WP series
