



21.5" PCAP 10pt touch screen with Android

Connect and go with the ProLite T2234AS-B1, the all-in-one monitor solution for shops, retail or information desks. This 21.5" PCAP 10-point touchscreen with Android allows users to directly connect and operate the monitor from any device. The HDMI output makes it easy to connect a second customer-facing display for dynamic content and advertising.

The robust screen comes with a rugged bezel and an IP65 rating, meaning the monitor is dust and water resistant from the front. Cables can be neatly tied with the special cable cover, so they cannot come loose or move around. Featuring IPS LCD screen technology, it offers exceptional colour performance and wide viewing angles, making it a perfect interactive display for instore retail.



Android OS

Thanks to Android OS, you can easily customize the display to your needs by installing applications directly to it.

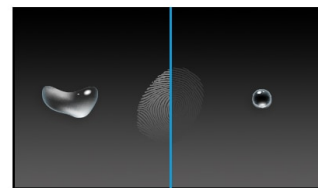

Anti-fingerprint coating

This special Nano coating ensures a smoother touch and less resistance in the swipe. It makes the screen less static and susceptible to dirt, dust, fingerprints and it improves the clarity of the content displayed on the screen.

01 DISPLAY CHARACTERISTICS

Design	Edge to edge glass
Diagonal	21.5", 55cm
Panel	IPS LED
Native resolution	1920 x 1080 (2.1 megapixel Full HD)
Aspect ratio	16:9
Brightness	350 cd/m ² typical
Brightness	305 cd/m ² with touch
Static contrast	1000:1 with touch
Light transmittance	87%
Response time	8ms
Viewing zone	horizontal/vertical: 178°/178°, right/left: 89°/89°, up/down: 89°/89°
Colour support	16.7mIn 8bit
Viewable area W x H	476.6 x 268.1mm, 18.8 x 10.6"
Pixel pitch	0.247mm
Bezel colour and finish	black, matte

02 TOUCH

Touch technology	projective capacitive
Touch points	10 (HID, only with supported OS)
Touch method	stylus, finger, glove (latex)
Touch interface	USB
Supported operating systems	All iiyama monitors are Plug & Play and compatible with Windows and Linux. For details regarding the supported OS for the touch models, please refer to the driver instruction file available in the downloads section.

03 INTERFACES / CONNECTORS / CONTROLS

Digital signal output	HDMI x1
Audio output	Speakers 2 x 2W
HDCP	yes
USB ports	x4 (2.0 x 3, 2.0 with OTG x1)
RS-232c	x1
RJ45 (LAN)	x1

04 FEATURES

Integrated software	Android 8.1 without GMS
CPU	Rockchip RK3288, quad-core Cortex-A17 up to 1.8GHz
GPU	Mali-T760 MP4
Storage	16GB eMMC
Memory	2GB DDR3
Graphics	1920 x 1080 @60Hz
WiFi	IEEE802.11b/g/n
Bluetooth	4.0
Extra	SD card slot, anti-fingerprint coating
Glass thickness	2.5mm

Glass hardness	7H
----------------	----

Water and dust protection	IP65 (front)
---------------------------	--------------

OSD key lock	yes
--------------	-----

05 GENERAL

Applications	install or uninstall, calculator, calendar, clock and alarm, manage contact information, manage emails, manage files, view photo album, web browser (Lightning), play audio files, update system online, search engine, system preferences, sound recorder, play video files, web browser (WebView)
--------------	---

Plug&Play	DDC2B
-----------	-------

06 MECHANICAL

Tilt angle	90° up; 5° down
------------	-----------------

VESA mounting	100 x 100mm
---------------	-------------

Cable management system	yes
-------------------------	-----

07 ACCESSORIES INCLUDED

Cables	power
--------	-------

Guides	quick start guide, safety guide
--------	---------------------------------

Other	AC adapter
-------	------------

Cable cover	yes
-------------	-----

08 POWER MANAGEMENT

Power supply unit	external
-------------------	----------

Power supply	DC 12 V
--------------	---------

Power usage	25W typical, 0.5W off mode
-------------	----------------------------

09 SUSTAINABILITY

Regulations	CE, CU, cULus, CCC
-------------	--------------------

Other	REACH SVHC above 0.1%: Lead
-------	-----------------------------

10 DIMENSIONS / WEIGHT

Product dimensions W x H x D	517.5 x 351.5 x 219mm
------------------------------	-----------------------

Weight (without box)	6.6kg
----------------------	-------

EAN code	4948570117178
----------	---------------

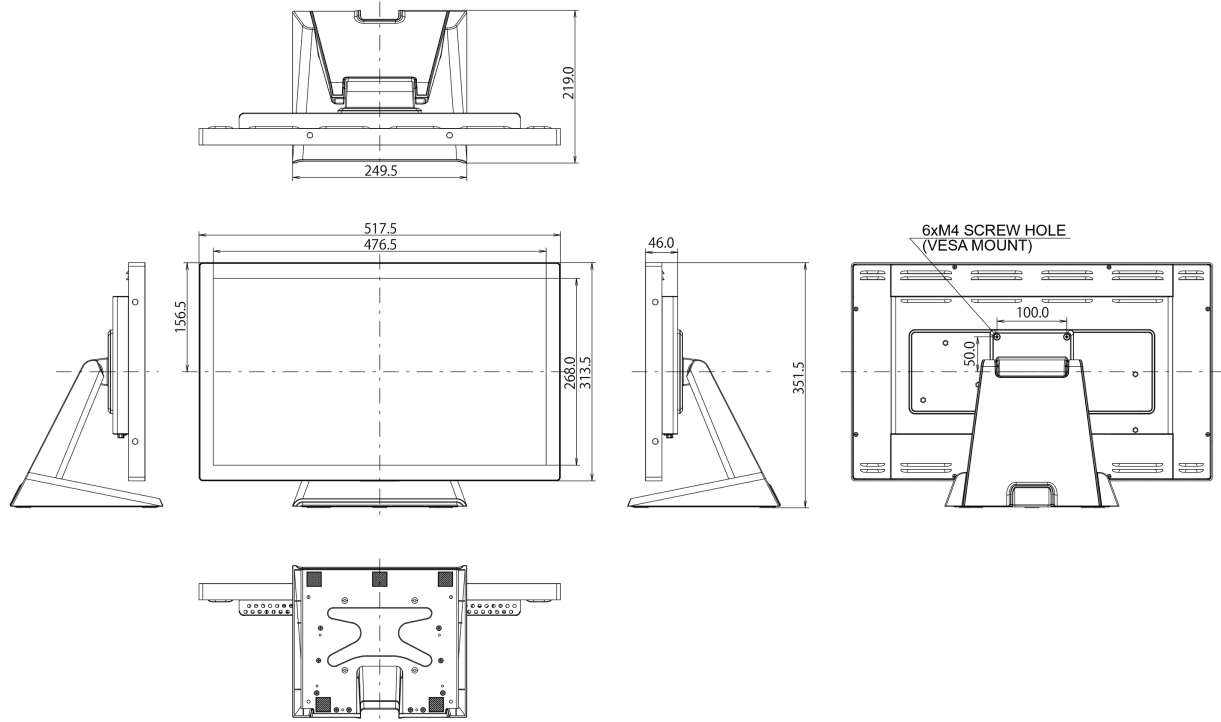

All trademarks and registered trademarks acknowledged. E & O E. Specification subject to change without notice. All LCD's comply with ISO-9241-307:2008 in connection with pixel defects.

© IIYAMA CORPORATION. ALL RIGHTS RESERVED