

# CV61

## Vehicle Mount Computer (Windows 7)

Model 1011CM01



**User Guide**

Intermec Technologies Corporation

Worldwide Headquarters

6001 36th Ave.W.

Everett, WA 98203

U.S.A.

[www.intermec.com](http://www.intermec.com)

The information contained herein is provided solely for the purpose of allowing customers to operate and service Intermec-manufactured equipment and is not to be released, reproduced, or used for any other purpose without written permission of Intermec Technologies Corporation.

Information and specifications contained in this document are subject to change without prior notice and do not represent a commitment on the part of Intermec Technologies Corporation.

© 2012 by Intermec Technologies Corporation. All rights reserved.

The word Intermec, the Intermec logo, Norand, ArciTech, Beverage Routebook, CrossBar, dcBrowser, Duratherm, EasyADC, EasyCoder, EasySet, Fingerprint, i-gistics, INCA (under license), Intellitag, Intellitag Gen2, JANUS, LabelShop, MobileLAN, Picolink, Ready-to-Work, RoutePower, Sabre, ScanPlus, ShopScan, Smart Mobile Computing, SmartSystems, TE 2000, Trakker Antares, and Vista Powered are either trademarks or registered trademarks of Intermec Technologies Corporation.

There are U.S. and foreign patents as well as U.S. and foreign patents pending.

# Contents

Before You Begin.....	v
Safety Information.....	v
Global Services and Support.....	v
Warranty Information.....	v
Web Support.....	v
Send Feedback.....	vi
Telephone Support.....	vi
Related Documents.....	vi
Patent Information.....	vii

<b>1 About the Vehicle Mount Computer.....</b>	<b>1</b>
About the CV61 Vehicle Mount Computer.....	2
Overview of CV61 Features.....	2
CV61 Accessories.....	4
Mount the CV61.....	6
Connect the CV61 to Power.....	6
Understand the Backup Power System.....	7
Check the Status of the Backup Battery.....	7
About the Ready-to-Work Indicator.....	8
Adjusting the Volume.....	9
About the Touch Screen.....	10
Adjust the Screen Brightness.....	10
Enable the Heated Touch Screen Defroster.....	11
Install an External Antenna.....	12
Force the Use of an External Antenna Connection.....	13
Attach an External Keyboard.....	14

<b>2 Understand the User Interface and Intermec Applications</b> .....	15
About the User Interface .....	16
About the Desktop Screen .....	16
Learn the Basic Skills .....	17
Use the Touch Screen .....	17
Calibrate the Screen .....	17
About the Taskbar .....	17
About Pop-Up Menus .....	18
Enter Information .....	18
Use Transcriber .....	19
About Intermec Applications .....	20
Applications Available on the CV61 .....	20
Applications You Can Download .....	21
About Intermec Browser .....	21
About Intermec Launcher .....	21
About Intermec Session Persistence Server (SPS) .....	21
About Intermec Terminal Emulator (ITE) .....	21
About SmartSystems Foundation .....	22
<b>3 Manage the Computer</b> .....	23
Manage the Computer in Your Network .....	24
Manage the Computer Using SmartSystems Foundation .....	24
Develop and Install Applications .....	25
Package Your Application .....	25
Install Applications Using SmartSystems Foundation Console .....	25
Install Applications Using a USB Storage Device .....	26
Install Applications Using an SD Card .....	26
Install Applications By Mapping To a Network Drive .....	26
Update the System Software .....	27
Update Individual or Multiple Computers Using the SmartSystems Console ..	27
Updating Individual Computers Using a USB Storage Device .....	28
<b>4 Configure the Computer</b> .....	31
How to Configure the Computer .....	32

- Use Intermec Settings on the Computer . . . . . 32
  - Start Intermec Settings . . . . . 33
  - About the Structure of Intermec Settings . . . . . 33
  - Navigate in Intermec Settings . . . . . 38
  - Restore Default Settings . . . . . 38
  - Hide Menu Items in Intermec Settings . . . . . 38
  - Use Intermec Settings Remotely With SmartSystems Foundation . . . . . 39
- Create and Enable Custom Profile Settings . . . . . 39
- About Network Communications . . . . . 40
  - Configure 802.11a/b/g/n (Wi-Fi) Radio Communications . . . . . 40
  - Configure Bluetooth Communications . . . . . 41
    - Connect to a Bluetooth Printer . . . . . 42
  - Create a VPN Server Connection . . . . . 43
- Connect a Scanner to the CV61 . . . . . 44
  - Connect to a USB Scanner . . . . . 44
    - Connect the SR30 or SR61T USB Scanner . . . . . 44
  - Connect to a Serially Tethered Scanner . . . . . 45
  - Connect to a Bluetooth Scanner . . . . . 47
- About Wireless Security . . . . . 48
  - Choose Between Microsoft and Wireless Security . . . . . 49
    - Select a Wireless Security Profile . . . . . 49
    - Select Microsoft as Your Security Choice . . . . . 54
  - Load a Certificate . . . . . 59

## **5 Troubleshoot and Maintain the Computer . . . . . 61**

- Troubleshoot Your Computer . . . . . 62
  - Troubleshoot the Wi-Fi Connection . . . . . 62
  - Troubleshoot 802.1x Security . . . . . 63
  - Check 802.11 Network Status . . . . . 63
  - Troubleshoot Reading Bar Codes . . . . . 64
  - Troubleshoot Operating the Computer . . . . . 67
- Call Product Support . . . . . 68
  - Find Your Configuration Number . . . . . 68
  - Find Your System Component Versions . . . . . 69
  - Find Your Operating System, BIOS and MCU Versions . . . . . 69
  - Find Your Service Pack Version . . . . . 70
- Restart Your Computer . . . . . 70

## Contents

Reboot the Computer . . . . .	70
Reset the Computer . . . . .	71
Clean the Computer. . . . .	71
<b>6 Upgrade the CV61 Vehicle Mount Computer . . . . .</b>	<b>73</b>
Upgrade the CV61 . . . . .	74
Upgrade the Hard Drive . . . . .	74
Upgrade Memory . . . . .	78
Install an SD Card . . . . .	81
<b>A Specifications and Default Settings . . . . .</b>	<b>85</b>
Physical and Environmental Specifications . . . . .	86
Physical Dimensions . . . . .	86
Environmental Specifications . . . . .	86
Power and Electrical Specifications . . . . .	86
Hardware . . . . .	86
Touch Screen Specifications . . . . .	87
Standard Communications . . . . .	87
Wireless LAN . . . . .	87
Default Configuration . . . . .	88
Data Collection Settings. . . . .	88
Communications . . . . .	91
Device Settings . . . . .	92
Core Messaging Service Settings. . . . .	93
RFID Settings . . . . .	93
Virtual Wedge Settings . . . . .	93
Common Lockdown Service Settings . . . . .	94
Device Monitor Settings. . . . .	95
Port Pin Assignments. . . . .	95
COM 1 and COM 2 Ports . . . . .	95
USB Port . . . . .	96
CANBUS Port . . . . .	97
Power Connector . . . . .	97
<b>B ScanNGo Wi-Fi Configuration Bar Codes . . . . .</b>	<b>99</b>
Radio Configuration Bar Codes . . . . .	100

2D Configuration Bar Codes.....100  
1D Configuration Bar Codes.....101

**Contents**



# Before You Begin

This section provides you with safety information, technical support information, and sources for additional product information.

## Safety Information

Your safety is extremely important. Read and follow cautions in this document before handling and operating Intermec equipment. You can be seriously injured, and equipment and data can be damaged if you do not follow the safety cautions.

This section explains how to identify and understand cautions and notes that are in this document.



**A caution alerts you to an operating procedure, practice, condition, or statement that must be strictly observed to prevent equipment damage or destruction, or corruption or loss of data.**



**Note:** Notes either provide extra information about a topic or contain special instructions for handling a particular condition or set of circumstances.

## Global Services and Support

### Warranty Information

To understand the warranty for your Intermec product, visit the Intermec website at [www.intermec.com](http://www.intermec.com) and click **Support > Returns and Repairs > Warranty**.

Disclaimer of warranties: The sample code included in this document is presented for reference only. The code does not necessarily represent complete, tested programs. The code is provided “as is with all faults.” All warranties are expressly disclaimed, including the implied warranties of merchantability and fitness for a particular purpose.

### Web Support

Visit the Intermec website at [www.intermec.com](http://www.intermec.com) to download our current manuals (in PDF).

Visit the Intermec technical knowledge base (Knowledge Central) at [www.intermec.com](http://www.intermec.com) and click **Support** > **Knowledge Central** to review technical information or to request technical support for your Intermec product.

### Send Feedback

Your feedback is crucial to the continual improvement of our documentation. To provide feedback about this manual, please contact the Intermec Technical Communications department directly at [TechnicalCommunications@intermec.com](mailto:TechnicalCommunications@intermec.com).

### Telephone Support

In the U.S.A. and Canada, call **1-800-755-5505**.

Outside the U.S.A. and Canada, contact your local Intermec representative. To search for your local representative, from the Intermec website, click **About Us** > **Contact Us**.

## Related Documents

This is a list of related Intermec documents.

- *[Intermec Settings Command Reference Manual](#)*
- *[Intermec Developer Library \(IDL\) Resource Kit Developer's Guide](#)*

The Intermec website at [www.intermec.com](http://www.intermec.com) contains our documents (as PDF files) that you can download for free.

### To download documents

- 1** Visit the Intermec website at [www.intermec.com](http://www.intermec.com).
- 2** Click the **Products** tab.
- 3** Using the **Products** menu, navigate to your product page. For example, to find the CV61 computer product page, click **Computers** > **Fixed Vehicle Computers** > **CV61**.
- 4** Click the **Manuals** tab.

If your product does not have its own product page, click **Support** > **Manuals**. Use the **Product Category**, the **Product Family**, and **Product** to find your documentation.

## **Patent Information**

Product is covered by one or more of the following patents:

5,218,191; 5,233,172; 5,241,488; 5,243,602; 5,258,606; 5,288,985;  
5,308,966; 5,342,210; 5,359,185; 5,389,770; 5,397,885; 5,414,251;  
5,416,463; 5,442,167; 5,464,972; 5,468,947; 5,468,950; 5,477,044;  
5,486,689; 5,500,516; 5,502,297; 5,504,367; 5,514,858; 5,534,684;  
5,536,924; 5,539,191; 5,541,419; 5,548,108; 5,550,362; 5,550,364;  
5,565,669; 5,572,007; 5,576,529; 5,594,230; 5,598,007; 5,608,578;  
5,616,909; 5,619,027; 5,640,001; 5,659,431; 5,672,860; 5,684,290;  
5,719,678; 5,729,003; 5,742,041; 5,761,219; 5,764,798; 5,777,308;  
5,777,309; 5,777,310; 5,786,583; 5,798,509; 5,798,513; 5,804,805;  
5,811,776; 5,811,777; 5,818,027; 5,821,523; 5,834,749; 5,837,987;  
5,841,121; 5,842,070; 5,854,478; 5,862,267; 5,869,840; 5,873,070;  
5,877,486; 5,878,395; 5,886,338; 5,895,906; 5,902,987; 5,902,988;  
5,912,452; 5,923,022; 5,936,224; 5,949,056; 5,969,321; 5,969,326;  
5,979,768; 5,987,192; 5,992,750; 6,003,775; 6,012,640; 6,016,960;  
6,018,597; 6,024,289; 6,034,379; 6,036,093; 6,039,252; 6,064,763;  
6,095,422; 6,097,839; 6,102,289; 6,102,295; 6,119,941; 6,128,414;  
6,138,915; 6,149,061; 6,149,063; 6,152,370; 6,155,490; 6,158,661;  
6,164,542; 6,164,545; 6,173,893; 6,195,053; 6,234,393; 6,234,395;  
6,249,008; 6,328,214; 6,330,975; 6,345,765; 6,356,949; 6,367,699;  
6,375,075; 6,375,076; 6,435,411; 6,484,944; 6,641,046; 6,669,087;  
6,681,994; 6,688,523; 6,732,930; 6,879,428; 6,889,903; 6,974,085;  
7,035,466; 7,143,941; 7,185,819; 7,190,835; 7,232,072; 7,322,526;  
6,847,620; 6,857,013; 6,944,446; 6,970,459; 6,976,062; 7,125,743;  
7,139,870; 7,159,764; 7,206,338; 7,208,916; 7,210,633; 7,271,679;  
7,298,791; 7,325,741; 7,327,988; 7,336,853; 7,451,441; 7,564,799;  
7,572,990; 7,580,395; 7,590,425; 7,633,550; 7,669,201; 7,761,864;  
7,888,913; 7,895,267; 7,924,346; 7,962,104; 8,002,173; 8,014,354;  
8,064,924.

There may be other U.S. and foreign patents pending.



# 1

## About the Vehicle Mount Computer

This chapter introduces the CV61 Vehicle Mount Computer with Windows® 7 operating system. Use this chapter to learn about the basic features and available accessories.

# **About the CV61 Vehicle Mount Computer**

The rugged CV61 Vehicle Mount Computer is designed for real-time data collection applications in warehousing, distribution, work-in-process, time and attendance, and stationary applications. The CV61 is highly configurable and runs on the Microsoft Windows 7 or Microsoft Windows XP Professional operating system. Additionally, the CV61 supports the use of terminal emulation applications, browser-based applications, or custom applications.

## ***CV61 Vehicle Mount Computer***

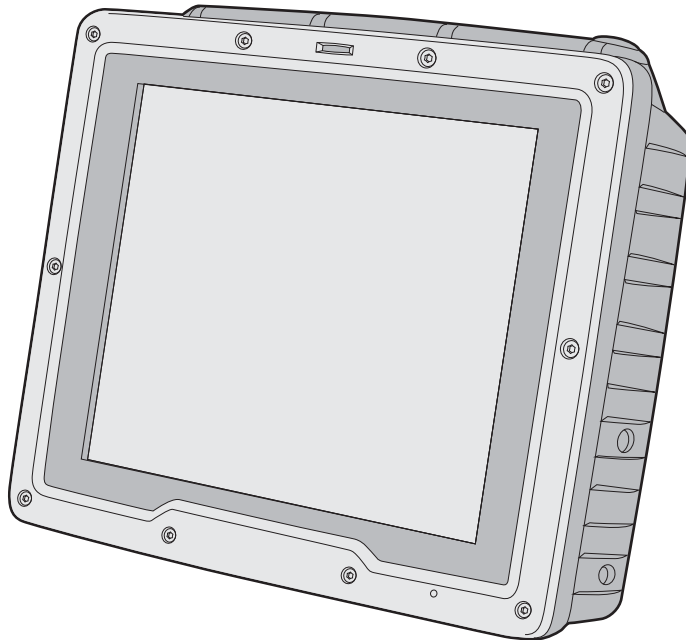

## **Overview of CV61 Features**

The CV61 includes these standard features:

- 12.1" color sunlight-readable XGA display
- two USB ports, two COM ports, a CANBUS port, keyboard connector, an Ethernet port, a speaker output jack, and a microphone/line stereo jack
- 40 GB solid-state hard drive

- 1 GB of RAM for Windows XP, 2 GB of RAM for Windows 7, both expandable to 3 GB of RAM
- Customer-accessible SD slot for memory cards up to 32 GB
- 802.11a/b/g/n and Bluetooth® radios
- Accelerometer
- Intel D425 1.8 GHz processor



The CV61 Vehicle Mount Computer has an IEEE 802.11a/b/g/n radio installed and is Wi-Fi® certified for interoperability with other 802.11a/b/g/n wireless LAN devices.

**CV61 Ports and Buttons**

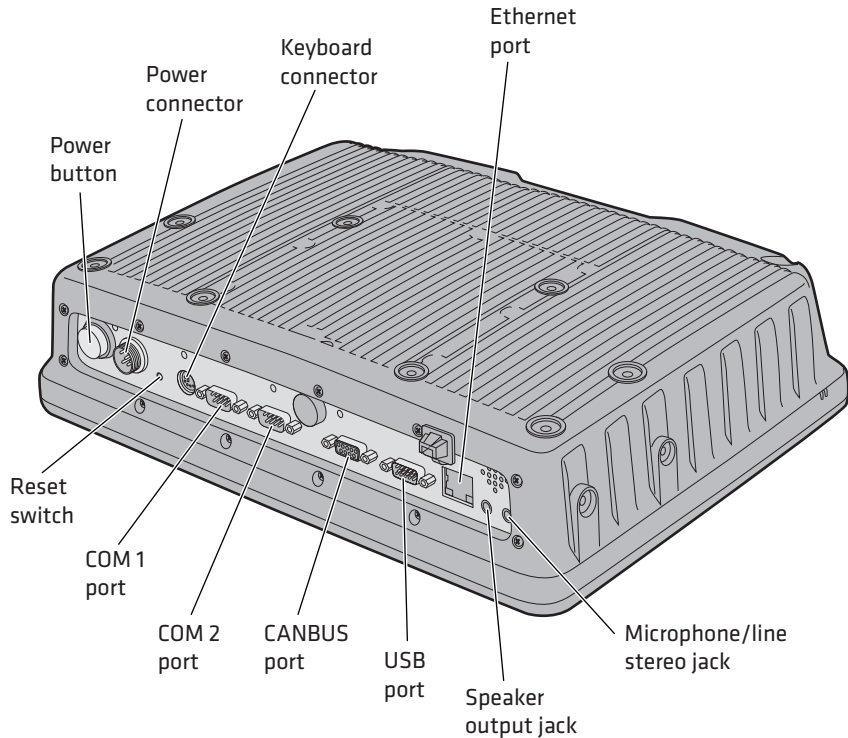

**CV61 Port and Buttons**

<b>Port and Buttons</b>	<b>Description</b>
Power button	Turns the CV61 on or off.
Power connector	Connect the CV61 to a vehicle battery, DC/DC external power supply, or an AC power supply.
Reset button	Perform a hard reset to the CV61.
Keyboard connector	Connect a PS2 keyboard to the CV61.
COM 1 and COM2 port	Connect RS-232 devices such as a printer or scanner to the CV61.
CANBUS port	Connect a CANBUS cable to allow devices to communicate with each other within a vehicle without a host computer.
USB port	Connect the CV61 USB cable accessory to allow two devices to communicate using the USB interface.
Ethernet port	Connect the CV61 to an Ethernet interface.
Speaker output jack	Connect headphones to the CV61.
Microphone/line out jack	Connect a microphone to the CV61.

## **CV61 Accessories**

The CV61 does not ship with any accessories. All accessories are sold and ordered separately. For help, contact your local Intermec sales representative.

**CV61 Accessories**

<b>Accessory</b>	<b>Description</b>
AC Power Supply	Use this power supply kit to supply AC power to the CV61. The AC power supply comes with a North American power cord. You need to purchase a country-specific power cord for your local power source.
CV61 Adapter Cable Kit	Use the CV61 adapter cable to connect the CV61 to an existing CV60 DC/DC power supply connection.



**CV61 Accessories (Continued)**

<b>Accessory</b>	<b>Description</b>
DC/DC (6-60 VDC) Power Supply	Use this power supply kit with 6-60 V powered vehicles requiring a 60 V or higher DC interface. This kit also provides power to the defroster.
DC/DC (15-96 VDC) Power Supply for Non-Heated Displays	Use this power supply kit with 15-96 V powered vehicles requiring a DC interface that is higher than 60 V. This kit does not provide power to the defroster.
DC/DC (15-96 VDC) High-Voltage Power Supply for Heated Displays	Use this power supply kit with 15-96 V powered vehicles requiring a DC interface that is higher than 60 V, and provide power to the defroster.
Direct Wiring Kit (9-60 VDC)	Use the direct wiring kit with 9-60 V powered vehicles. This kit provides a direct connection between the CV61 and the vehicle battery.
Keyboard	Use the CV61 keyboard to input text. The keyboard is rugged and has an IP65 seal rating.
Desktop Mounting Kit	Use the desktop mounting kit to attach the CV61 to a flat surface such as a desktop.
Vehicle Mounting Kit	Use the vehicle mounting kit to attach the CV61 to a vehicle such as a forklift or truck.
Keyboard Mounting Kit	Use the keyboard tray mounting kit to attach the CV61 keyboard to the CV61.
Screen Protector Kit	Use the screen protector to protect the CV61 screen from scratches and debris.
SDRAM Upgrade Kit	Use the SDRAM upgrade to add memory to the CV61. You can purchase a 1 or 2 GB upgrade.
External 802.11 a/b/g antenna	Dual band 2.4 GHz and 5.0 GHz sealed remote mount antenna. Supports 802.11 a/b/g only.
Omnidirectional antenna	Single-band omnidirectional remote mount antenna. Supports 802.11 b/g/n only.

### CV61 Accessories (Continued)

Accessory	Description
Cable Retention Kit	Use the cable retention kit to keep your cables secure and prevents accidental access to the power switch.
Backup Battery Replacement Kit	If the CV61 backup battery fails, purchase this kit to replace the internal backup battery.
Replacement Touch Panel Kit	If the CV61 touch panel stops responding, you may need to purchase this kit to replace the touch panel.
CV61 USB Cable	Use the USB cable to connect USB devices and peripherals to the CV61. The USB cable provides dual USB type A host connectors and includes cable restraints.

## Mount the CV61

To properly mount the CV61 to a desktop or vehicle, you must purchase a mounting kit. Use of any other kits for the CV61 may prematurely damage the computer or void the product warranty. For more information, contact your local Intermec representative.

There are two types of mounting kit options sold separately:

- Standard Vehicle Mounting Kit
- Desktop Mounting Kit

For more information on installing the mounting kits, see one of the mounting kit instructions located on the Intermec website at [www.intermec.com](http://www.intermec.com).

## Connect the CV61 to Power

For the CV61 to operate, you must provide power to the CV61 through a DC/DC or AC/DC power supply. There are a variety of power options for the CV61. You must order one of these power options separately:

- DC/DC Power Supply Kit (6-60 VDC) for heated displays
- DC/DC Power Supply Kit (15-96 VDC) for non-heated displays
- DC/DC Dual Power Supply Kit (15-96 VDC) for heated displays

- Direct Wiring Kit (9-60 VDC)
- CV61 Adapter Cable Kit
- AC Power Supply Kit

Use the CV61 adapter cable to connect the CV61 to an existing CV60 DC/DC installation. If you are using the CV61 with the Desktop Mounting Kit, use the AC power supply and power cord. For more information on power supply options, contact your local Intermec representative.

## **Understand the Backup Power System**

The CV61 has backup battery that has enough capacity to maintain a network connected state for up to 30 minutes if power is removed (for example, during a forklift battery change). When power is restored, the CV61 resumes normal operation.

An internal charger automatically charges the backup battery within 8 hours when external power is supplied. If the backup battery fails, a fault is displayed in the CV61 Properties screen.

## **Check the Status of the Backup Battery**

Check the status of the internal battery to know how much battery life you have left.

- 1** Tap **Start > Control Panel**.
- 2** In the **View by:** drop-down menu, select either **Large** or **Small icons**.
- 3** Double-tap **CV61 Properties**. The backup battery status is shown in the System Information section of the CV61 Properties screen.

System Information	
BIOS Version:	3039
MCU Version:	MCU0011.P2
OS Image Version:	WIN7_0007
Backup Battery Status:	Charging

If the **Backup Battery Status** displays **Fault**, you need to replace the backup battery.

## About the Ready-to-Work Indicator

The Ready-to-Work indicator shows the status of the CV61.

### **Ready-to-Work Indicator Location**

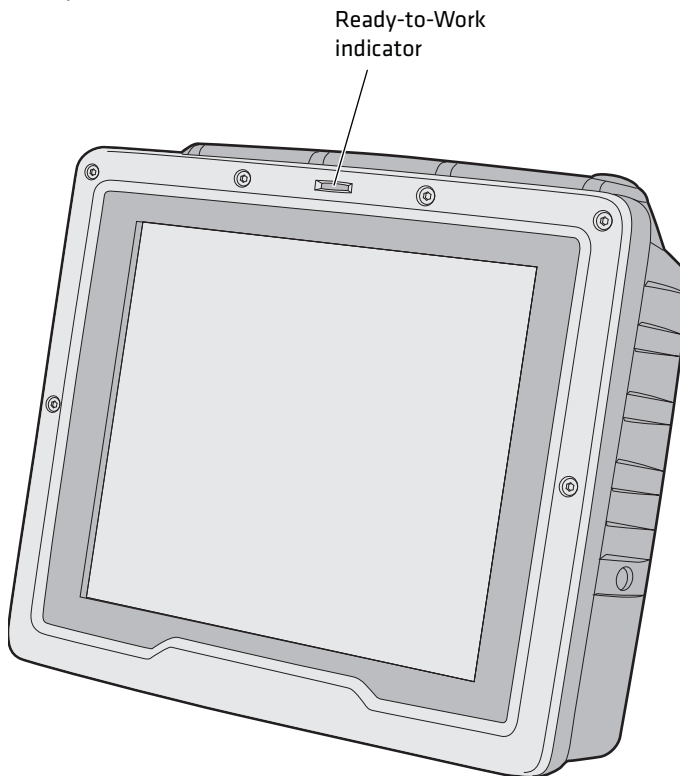

Use the following table to learn about the indicator default status. For further customization, you can enable or disable the Ready-to-Work indicator in Intermec Settings. For more information, see **“Start Intermec Settings” on page 33**.

**Ready-to-Work Indicator Status**

LED	Description
On	The CV61 is powered on.
Blinking	The indicator blinks when: <ul style="list-style-type: none"><li>• the CV61 is in state maintenance mode.</li><li>• DC power is disconnected.</li><li>• attempting to boot at -20 °C (-4 °F) or below.</li></ul>
Off	The CV61 is off.

## Adjusting the Volume

You can change the CV61 volume, for sounds you hear when you tap the screen or scan bar codes with a scanner.

- 1 Tap the speaker icon in the taskbar.



- 2 Move the speaker slider up or down, or tap the speaker icon in the slider to turn the volume on or off.

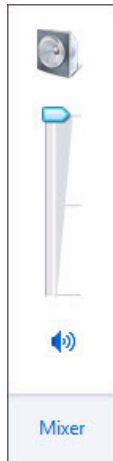

## **About the Touch Screen**

The CV61 has a 12.1” color XGA touch screen display with a resolution of 1024 x 768 pixels. The display may also come with an optional heated touch screen defroster to reduce condensation on the external surface of the display when moving between sub-freezing temperatures and normal temperatures.

If you are going to use the CV61 in extreme cold conditions for an extended period of time, you should turn on the power at room temperature for at least 15 minutes prior to using it. This process of “warming up” helps preserve the lighting on the display.

## **Adjust the Screen Brightness**

You can adjust the brightness of the screen manually or enable the ambient-light sensor to automatically adjust the brightness of the CV61.

- 1** Tap **Start > Control Panel**.
- 2** In the **View by:** drop-down menu, select either **Large** or **Small icons**.
- 3** Double-tap **CV61 Properties**. The screen brightness is shown in the Screen Control section of the CV61 Properties screen.

- 4 To manually adjust the screen brightness, make sure **Adaptive Brightness Control** is not selected and use the slider to change the screen brightness.

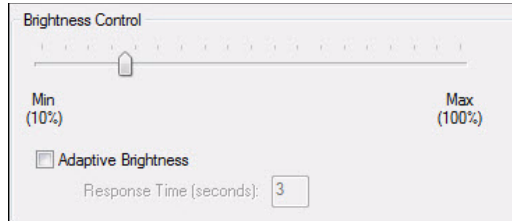

To enable the ambient light sensor, select **Adaptive Brightness Control** and enter a response time in the text box.

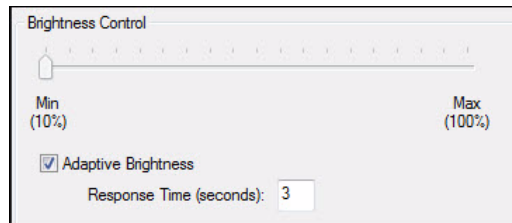

- 5 Tap **Apply** to save your changes.
- 6 Tap **OK** to exit the CV61 Properties menu.

## Enable the Heated Touch Screen Defroster

If you have a heated touch screen defroster, use it to help reduce condensation on the display when you are moving between sub-freezing and normal temperatures.

Use the following procedure to learn how to turn the heater on, off, or leave it on an automatic setting. When the defroster is set to automatic, the defroster automatically turns on when the external temperature reaches 3 °C (37 °F) and below, and turns off when the temperature reaches 5 °C (41 °F).

- 1 Tap **Start > Control Panel**.
- 2 In the **View by:** drop-down menu, select either **Large** or **Small icons**.

- 3** Double-tap **CV61 Properties**. The heater information is shown in the Heater section of the CV61 Properties screen.
- 4** Select **Heater On**, **Heater Off**, or **Automatic On/Off**.

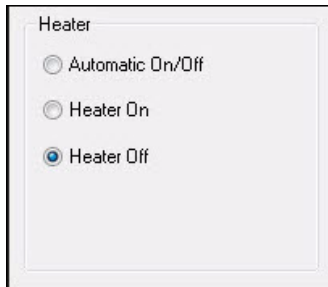

- 5** Tap **Apply** to save your changes.
- 6** Tap **OK** to exit the CV61 Properties menu.

## **Install an External Antenna**

You can purchase an antenna to mount on a wall, forklift, or other flat surface using either screws or small patches of adhesive-backed hook and loop fastener material.

Since system performance and antenna polarization are site-dependent, a permanent mounting location may require some experimentation. In most fixed installations, you should mount the antenna initially in a vertically-polarized position, with the cable from the antenna parallel to the floor and ceiling.

- 1** Remove the antenna cover.



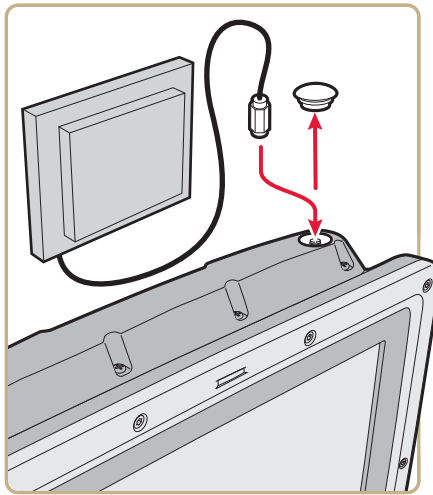

- 2 Secure the antenna to the CV61 antenna plug.
- 3 Using your own hardware, secure the external antenna to a wall, forklift, or other flat surface.

## Force the Use of an External Antenna Connection

If an external antenna is connected, the CV61 automatically detects the connection and disables the internal antenna and uses the external antenna. However, if the external antenna is not detected, you can force the use of the external antenna through the CV61 Properties screen.

- 1 Tap **Start > Control Panel**.
- 2 In the **View by:** drop-down menu, select either **Large** or **Small icons**.
- 3 Double-tap **CV61 Properties**. The external antenna information is shown in the External Antenna section of the CV61 Properties screen.
- 4 Select **Force External Antenna**.

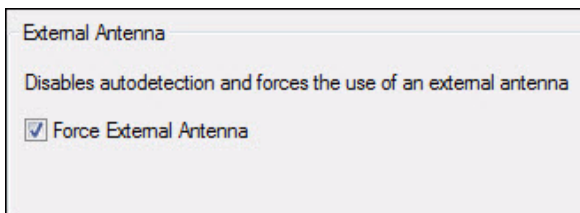

- 5 Tap **Apply** to save your changes.
- 6 Tap **OK** to exit the CV61 Properties menu.

## **Attach an External Keyboard**

You can use either a PS/2 or USB keyboard with the CV61. Intermec recommends you use the CV61 rugged keyboard to input text. For more information on purchasing an Intermec keyboard, contact your local Intermec representative.

### **CV61 External PS/2 Keyboard**

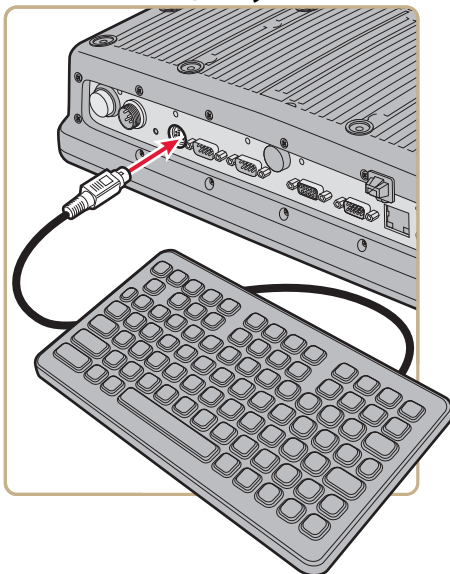

# 2

## Understand the User Interface and Intermec Applications

Use this chapter to learn about the Windows 7 user interface and how to interact with the screen. You can also use this chapter to learn about the Intermec applications on the CV61, as well as additional Intermec applications you can download.

## About the User Interface

The user interface for the Windows 7 operating system is similar to using your desktop PC. The interface is touch-friendly and easy to navigate. Use the following sections to understand how to interact with Windows 7 on the CV61.

### About the Desktop Screen

When you turn on your computer, the Desktop screen is the first screen that appears, unless Intermec Terminal Emulator (ITE) is configured to automatically launch. The Desktop screen contains the Desktop and the Taskbar.

#### **Windows 7 Default Screen**



Tap **Start > Help and Support**, then select a topic on the computer to find additional information on Windows 7 components.

## Learn the Basic Skills

Learning to use the computer is easy. This section describes the basic concepts of using and customizing the vehicle mount computer and Windows 7.

### Use the Touch Screen

Use your finger or stylus to move around the CV61 user interface.

#### *Touch Screen Navigation*

Action	Description
Tap	Tap the screen once with your stylus or finger to select options, open or close applications, or launch menus.
Double-tap	Double-tap the screen with your stylus or finger to launch applications.
Drag	Hold your stylus or finger on the screen and drag across the screen to select text and images.
Tap and hold	Tap and hold your stylus or finger, when the circle appears, remove the stylus or finger from the screen to see a menu of actions available for that item. On the pop-up menu that appears, tap the action you want to perform.

### Calibrate the Screen

You may need to calibrate your screen if you tap on one area and it registers in a different area of the screen. Make sure you use the stylus to complete the alignment process.

- 1 Tap **Start > All Programs > UPDD > Calibrate**. The Calibration Wizard appears.
- 2 Follow the prompts on the screen to complete the alignment process.

### About the Taskbar

The Taskbar is located at the bottom of the screen. It displays information such as the Start menu icon, the current time, the Input panel icon, and the current status of information such as Wi-Fi signal strength or Bluetooth connectivity.

**Windows 7 Taskbar**



For more information on Windows 7 icons, tap **Start** > **Help**, then select a topic on the computer to find additional information on Windows 7 components.

## About Pop-Up Menus

Use pop-up menus to quickly perform an action on an item. For example, you can use a pop-up menu to delete or make a copy of an item. To access a pop-up menu, tap and hold the item on which you want to perform the action. When the menu appears, tap the action you want to perform, or tap anywhere outside the menu to close the menu without performing the action.

**Windows 7 Pop-Up Menu**

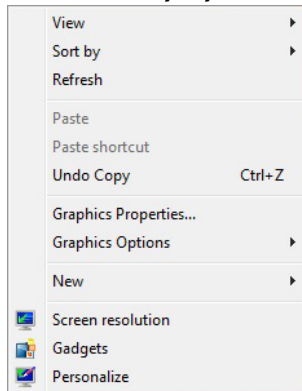

## Enter Information

If you do not use the external keyboard, enter information on the vehicle mount computer by using the onscreen keyboard or write using Transcriber.

- 1 Make sure that the Input Panel icon is displayed on the taskbar.



If the input panel is not displayed, tap and hold your stylus or finger on the taskbar until a circle appears, and remove your stylus or finger from the screen. A pop-up menu appears.

- 2 Select **Toolbars** and select **Tablet PC Input Panel**. The input panel is placed on the taskbar.
- 3 Tap the Input Panel icon to bring up the onscreen keyboard.



## **Use Transcriber**

Use Transcriber to write on the screen using a stylus just as you would on paper. You can write an entire sentence of information, and then pause to let Transcriber change the written characters to typed characters.

- 1 Tap the **Input Panel** icon on taskbar.
- 2 Tap the **Transcriber** icon.

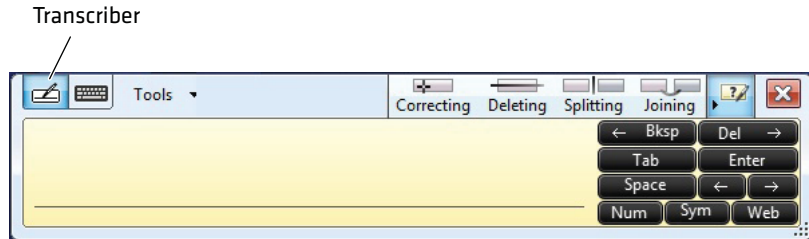

- 3 Write anywhere on the transcriber window. Pause and let Transcriber change the written characters to typed characters.



## About Intermec Applications

Intermec provides many useful applications to help you configure, troubleshoot, and connect your computer to other devices and networks. You can also download additional applications from the Intermec website to help you use all of the features of your computer.

### Applications Available on the CV61

Use this table to understand some of the Intermec applications on the CV61.

#### ***Intermec Applications Available on the CV61***

<b>Icon</b>	<b>Application</b>	<b>Description</b>
	Intermec Settings	Use Intermec Settings to configure your computer. You can use Intermec Settings to individually configure a computer or you can use it through SmartSystems to configure all of your computers.
	Bluetooth Printing	Use the Bluetooth Printing application to connect to a Bluetooth printer.
	Bluetooth Scanning	Use the Bluetooth Scanning application to connect to a Bluetooth scanner.



## **Applications You Can Download**

You can download several Intermec applications from the Intermec website to extend the capabilities of the CV61. All of the applications listed below are available from the Intermec website. Some of the applications require the purchase of a license to run. To find the application you want, go to [www.intermec.com](http://www.intermec.com) > **Support** > **Downloads** and then enter the information to find the CV61 software that you can download.

### **About Intermec Browser**

Intermec Browser is a locked-down web application for your computer that is compatible with Internet Explorer 6.0. You can configure Intermec Browser for your specific application requirements and design your own web pages. You can download and use Intermec Browser for a 60-day evaluation period. After the evaluation period expires, you will need to purchase a license.

### **About Intermec Launcher**

Intermec Launcher is a Microsoft Windows application, designed for Intermec computers, that provides a platform from which other applications may be launched while attempting to provide a locked-down environment. You can configure Intermec Launcher for your specific application requirements. You can download and use Intermec Launcher for a 60-day evaluation period. After the evaluation period expires, you will need to purchase a license.

### **About Intermec Session Persistence Server (SPS)**

Intermec Session Persistence Server enables persistence of an ITE session on a computer when a client is momentarily disconnected, which includes Intermec computers that go out of range, go to sleep, or are suspended.

### **About Intermec Terminal Emulator (ITE)**

Intermec Terminal Emulator (ITE), part of Intermec Client Pack (ICP), is a terminal emulation client designed for enterprise-level data collection.

ITE is packed with enhancements that improve productivity, reduce errors, and deliver fast return on investment. It supports multiple emulation protocols in a single client and has new features such as session persistence, remote management and configuration, and offers a maintenance plan to keep you up-to-date with the latest releases and upgrades. You can download and use ITE for a 60-day evaluation period. After the evaluation period expires, you will need to purchase a license and a maintenance plan.

### **About SmartSystems Foundation**

SmartSystems™ Foundation is an easy-to-use software platform that provides IT Administrators and Integrators a single, integrated portal for hands-free provisioning, deployment, and management of Intermec devices minimizing the effort spent on software upgrades, equipment monitoring, maintenance and troubleshooting.

SmartSystems Foundation provides a consistent way to manage Intermec devices including mobile computers, vehicle mount computers, RFID readers, printers and bar code scanners, located on-site or remote, to make the most of limited IT resources, and lower the total cost of ownership for Intermec data collection equipment. SmartSystems Foundation can be downloaded at no charge from the Intermec website. For more information, visit [www.intermec.com/SmartSystems](http://www.intermec.com/SmartSystems).

# 3

## Manage the Computer

Use this chapter to learn how to remotely update, configure, and monitor the CV61. You will also find information on installing and developing software applications as well as how to upgrade the system software.

# Manage the Computer in Your Network

When you have multiple computers and peripherals in your network, it is essential to have an easy way to manage updates, configure all of the devices, and remotely troubleshoot problems. Intermec provides a free device management software platform called SmartSystems™ Foundation to help you manage your devices. You can also purchase third-party device management software through a vendor.

## Manage the Computer Using SmartSystems Foundation

SmartSystems Foundation is a software platform that lets you manage all of your SmartSystems-enabled devices simultaneously from a central server. The SmartSystems Foundation console displays all SmartSystems-enabled computers and peripherals in your network.

### Intermec SmartSystems Foundation Console

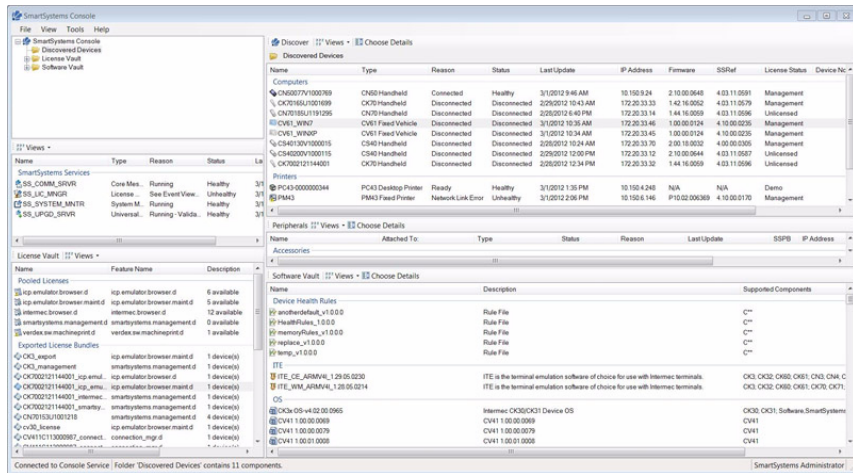

Through the console, you can:

- drag-and-drop configuration bundles, operating system updates, and firmware upgrades to multiple computers.
- save configuration settings from a single device and deploy those settings to many devices simultaneously.
- remotely change settings on SmartSystems-enabled computers and peripherals.

The SmartSystems Foundation console can report on asset locations and battery status, making it easier to manage your devices.

With a Provisioning license, SmartSystems Foundation can automatically push software, configuration settings, and other files to connected computers. The license also enables ScanNGo, which makes connecting additional computers to your wireless network as easy as reading bar codes. You can download SmartSystems Foundation from the Intermec website at no charge. For more information, visit [www.intermec.com/SmartSystems](http://www.intermec.com/SmartSystems). To purchase a Provisioning license, contact your local Intermec sales representative.

## **Develop and Install Applications**

Use the Intermec Resource Kits to develop applications to run on the computer. The Resource Kits are a library of C++, .NET, Java, and web components grouped by functionality that you can use to create applications for the computer. The Resource Kits are part of the Intermec Developer Library (IDL), and can be downloaded from the Intermec website at [www.intermec.com/idl](http://www.intermec.com/idl).

For more information, see the *Intermec Developer Library Resource Kit Developer Guide*.

## **Package Your Application**

For very simple applications, the executable file may be the only file you need to deploy. More typically, you will have a set of files to install.

Intermec recommends using .exe files to install your applications. The computer uses standard .exe files and will install third-party .exe files.

## **Install Applications Using SmartSystems Foundation Console**

You can use the SmartSystems console to drag-and-drop Intermec applications onto your computer. The console is part of SmartSystems Foundation.

- 1 Download your application file from the Intermec website and unzip it on your desktop PC.

- 2 Double-click the application file to install it. The application file should appear in the Software Vault.
- 3 From the SmartSystems console in the Software Vault, drag-and-drop the application onto each computer in your network, or drop the application on a group of computers contained in a folder.

## **Install Applications Using a USB Storage Device**

You can use a USB storage device to install applications onto your computer one at a time or if you have no network connection. To connect a USB storage device to the CV61, you need to purchase a CV61 USB cable. For more information, contact your local Intermec representative.

- 1 Copy your application file to the USB storage device.
- 2 Connect the CV61 USB cable and the USB storage device into the computer.
- 3 Click **Open folder to view files** when the pop-up screen appears.
- 4 Click the executable file to install the application to the computer.

## **Install Applications Using an SD Card**

Use an SD card to install applications on one computer at a time or if you have no network connection.

- 1 Copy your application file to the storage card.
- 2 Install the SD card in the CV61.
- 3 On the CV61, browse to the **SD Card** folder and run your application.

## **Install Applications By Mapping To a Network Drive**

Map to a network drive so that you can transfer files to your computer.



**Note:** You may need to contact your IT department to map to certain drives.

- 1 On the computer, select **Start** > **Computer** > **Map Network Drive**. The Map Network Drive screen appears.
- 2 In the **Drive** menu, select the drive letter you want to assign the network drive.
- 3 In the **Folder** menu, type in the directory you want to map. You can also browse for the directory by tapping on the **Browse** button.
- 4 Tap **Finish** to map the network drive.
- 5 Browse to the network drive and transfer any files you want to install to your computer.

## Update the System Software

The computer uses SmartSystems bundles to update system software. You can use these methods to update your computer:

- You can update individual computers, or multiple computers at the same time using the SmartSystems console. For help, see the next section, **Update Individual or Multiple Computers Using the SmartSystems Console**.
- You can update individual computers using a USB storage device.

**Note:** To learn how to update Windows 7, see the Microsoft website at [www.microsoft.com](http://www.microsoft.com).



## Update Individual or Multiple Computers Using the SmartSystems Console

You can use the SmartSystems console to update the operating system or system software on your computer. The console is part of SmartSystems Foundation and is available from the Intermec website. Before you can update your computer, you need:

- SmartSystems Foundation. To download SmartSystems Foundation, go to [www.intermec.com/SmartSystems](http://www.intermec.com/SmartSystems) and click the **Downloads** tab.
- the SmartSystems bundles you want to install. These SmartSystems bundles are available from the Intermec website at

[www.intermec.com](http://www.intermec.com). Go to **Support > Downloads > OS/Firmware/Drivers** list.

After you have located these items, you can update your computer using SmartSystems Foundation.

- 1 Open the SmartSystems console.
- 2 Make sure the computer is Discovered.
- 3 Download the SmartSystems bundle to your PC.
- 4 Double-click the SmartSystems bundle on your PC to extract the update files to the Software Vault.
- 5 From the SmartSystems console, locate the bundle to install and drag them to each computer (or group in a folder) you want to update. The SmartSystems console installs the update on your computers.

After the download is complete, your computer begins the update process and automatically reboots and installs the bundle onto your computer.



**Note:** The SmartSystems console indicates that your computer is offline, by displaying a red stop symbol, until the computer reboots and reconnects to the system.

## Updating Individual Computers Using a USB Storage Device

You can transfer upgrade bundles from your desktop PC to your computer using a USB storage device. Before you can update your computer, you need:

- the SmartSystems bundles you want to install. These SmartSystems bundles are available from the Intermec website at [www.intermec.com](http://www.intermec.com). Go to **Support > Downloads > OS/Firmware/Drivers** list.
- a USB storage device.

After you have located these items, you can update your computer.

- 1 Download the SmartSystems bundle to your PC and note the download location.
- 2 Transfer the bundle file to the USB storage device.



- 3** Insert the USB storage device into the CV61.
- 4** Run the CV61 installer .exe from within the bundle.
- 5** Follow the onscreen instructions to update your computer.



# 4

## Configure the Computer

Use this chapter to learn about the available methods for configuring the CV61 and how to use Intermec Settings. You can also use this chapter to learn how to configure network communications and wireless security.

# How to Configure the Computer

You can configure many parameters on the computer such as the bar code symbologies it decodes or the network settings. The values you set for these parameters determine how the computer operates.

There are several ways to configure the computer:

- Directly on the computer. You can use Intermec Settings directly on the computer to change only the settings on that computer. For more information, see the next section.
- Remotely using Intermec SmartSystems Foundation. When you use SmartSystems, you can remotely configure all of your CV61 Vehicle Mount Computers as well as other SmartSystems-enabled Intermec computers and peripherals. For more information, see [“Use Intermec Settings Remotely With SmartSystems Foundation” on page 39](#).

You can also configure the computer with configuration bundles that you create using SmartSystems Foundation. For more information, see the SmartSystems Foundation Online Help.

## Use Intermec Settings on the Computer

Use Intermec Settings to configure parameters for Intermec applications on the computer as well as some device-specific parameters like the screen brightness. You can configure parameters for important functions like data collection and communications.

External bar code scanners are supported by connecting the scanner to a COM port, USB port, or by Bluetooth. When configuring a scanner using Intermec Settings, the scanner symbologies can be updated through the CV61 data collection software.

## Start Intermec Settings

Intermec Settings is located in the Control Panel.

- 1 Tap **Start > Control Panel**.
- 2 In the **View by:** drop-down menu, select either **Large** or **Small icons**.
- 3 Double-tap the **Intermec Settings** icon. The Intermec Settings Main Menu appears.



## About the Structure of Intermec Settings

Use the tables below to help find the parameters in Intermec Settings that you want to configure. Each table contains the parameters for one of the Intermec Settings Main Menu options.

If you see > next to a menu option, there are more screens available in the next level. If you see ... next to a menu option, there is only one more screen available.

Most parameters are saved as soon as you tap **OK**. Some settings require you to reboot the computer for the changes to take effect.

**Data Collection Menu**

<b>Data Collection Options</b>	<b>Parameters You Can Configure</b>
Tethered Scanner (COM 1)	<ul style="list-style-type: none"> <li>• Enable scanner port</li> <li>• Symbologies</li> <li>• Symbology options</li> <li>• Scanner port settings</li> <li>• Imager settings</li> <li>• Decode security</li> </ul>
Tethered Scanner (COM 2)	<ul style="list-style-type: none"> <li>• Enable scanner port</li> <li>• Symbologies</li> <li>• Symbology options</li> <li>• Scanner port settings</li> <li>• Imager settings</li> <li>• Decode security</li> </ul>
Bluetooth Scanner	<ul style="list-style-type: none"> <li>• Symbologies</li> <li>• Symbology options</li> <li>• Scanner settings</li> <li>• Bluetooth scanner settings</li> <li>• Scanner port settings</li> <li>• Decode security</li> </ul>
USB Scanner	<ul style="list-style-type: none"> <li>• Symbologies</li> <li>• Symbology options</li> <li>• Scanner settings</li> <li>• Bluetooth scanner settings</li> <li>• Scanner port settings</li> <li>• Decode security</li> </ul>
BT-Configure on Connect	Bluetooth-configure on connect
Enable USB scanner auto-detect	Enable USB scanner auto-detect

**Communications Menu**

<b>Communications Options</b>	<b>Parameters You Can Configure</b>
Device Name	Device name

<b>Communications Options</b>	<b>Parameters You Can Configure</b>
802.11 Radio	<ul style="list-style-type: none"> <li>• Radio enabled</li> <li>• Security choice</li> <li>• Wireless security</li> <li>• IP Settings</li> <li>• Certificates</li> <li>• Radio bands</li> <li>• Allow security changes</li> </ul>
Ethernet Adapter	IP settings (DHCP, DHCP client identifier, IP address, subnet mask, default router, primary DNS, and secondary DNS)
Bluetooth	Bluetooth settings (power, discoverable, connectable, and so on)

**Device Settings Menu**

<b>Device Settings Options</b>	<b>Parameters You Can Configure</b>
Antenna	Force external antenna
Date and Time	Date and time settings
IDL Runtime Versions	<ul style="list-style-type: none"> <li>• ITC 50 (read-only)</li> <li>• ITCScan (read-only)</li> </ul>
Power Management	Tethered device power
PS/2	PS/2 port access
Screen	<ul style="list-style-type: none"> <li>• Brightness</li> <li>• Adaptive brightness</li> <li>• Screen blanking on motion</li> </ul>
System Component Versions	System component versions (read-only)

**Printer Menu**

<b>Printer Options</b>	<b>Parameters You Can Configure</b>
Printer (if connected through Bluetooth)	Printer settings (Auto detect printer, memory, display, and so on)



**Note:** The Printer menu displays settings for Bluetooth connected printers. The settings that appear in the menu are dependent on the printer that is paired with the device. The printer needs to be using the Wireless Printing application.

### **RFID Menu**

<b>RFID Options</b>	
RFID	Enable RFID service

### **Virtual Wedge Menu**

<b>Virtual Wedge Options</b>	<b>Parameters You Can Configure</b>
Enable Virtual Wedge	Enable virtual wedge
Virtual Wedge Method	Virtual wedge method
Bar Code Scanner Wedge	<ul style="list-style-type: none"><li>• Bar code scanner grid</li><li>• Label encoding (code page)</li></ul>
RFID Reader Wedge	<ul style="list-style-type: none"><li>• Read command</li><li>• User-defined read command</li><li>• Date and time</li><li>• Tag separator</li><li>• User-defined tag separator</li><li>• End of message</li><li>• User-defined end of message</li><li>• RFID reader grid</li></ul>

### **Common Lockdown Service Menu**

<b>Common Lockdown Service Options</b>	<b>Parameters You Can Configure</b>
Server	<ul style="list-style-type: none"><li>• Port</li><li>• Maximum client connections</li><li>• Enable server</li></ul>
Lockable Keys	<ul style="list-style-type: none"><li>• Enable Windows key</li><li>• Enable Task Manager key</li><li>• Enable Task Switcher key</li><li>• Enable Windows Security Dialog key</li><li>• Enable Closing Applications key</li><li>• Enable Minimize key</li><li>• Enable New Session key</li></ul>

### **License Manager Menu**

<b>License Manager Options</b>	<b>Parameters You Can Configure</b>
About	About settings (read-only)



License Manager Options	Parameters You Can Configure
License Vault	None (displays applications that are licensed)

### **Device Monitor Menu**

Device Monitor Options	Parameters You Can Configure
Device Health Controls	<ul style="list-style-type: none"> <li>• Enable health data collection</li> <li>• Enable Blue light (LED)</li> <li>• Set rule file location</li> <li>• Set data refresh periods</li> </ul>

### **SmartSystems Information Menu**

SmartSystems Information Options	Parameters You Can Configure
Identity	Identity information (hardware version, firmware version, OS version, and so on) (read-only)
Administrator	Administrator settings (name, phone, and email)
Location	Location settings (country, state, city, campus, and detail)
Information	Device Notes (read-only)

### **Core Messaging Service Menu**

Core Messaging Service Options	Parameters You Can Configure
Server IP	Server IP (read-only)
Associated Server IP	Associated server IP
Broadcast Name	Broadcast name
Port	Port (read-only)
Keep Alive Ping Interval	Keep alive ping interval

For more information on all parameters in Intermec Settings, see the [\*Intermec Settings Command Reference Manual\*](#).

## Navigate in Intermec Settings

You can easily navigate through the screens in Intermec Settings to find the parameter you need to configure.

To move down a level in Intermec Settings:

- Tap the menu item in the list.

To move back a level in Intermec Settings:

- Tap **Back** or **Cancel** on the Tile bar.

To save a parameter setting:

- Tap **OK**.

To exit Intermec Settings:

- Tap **Menu** > **Exit** or **OK**.

## Restore Default Settings

You can easily restore a menu to its default settings or all of the Intermec Settings parameters to their default settings if necessary.

- 1 Navigate to the menu that you want to restore to defaults.
- 2 Tap **Menu** > **Restore Menu Defaults**.
- 3 When prompted, tap **Yes** to restore the menu default settings.
- 4 If prompted to refresh the computer, tap **Yes**.

You can restore defaults settings for all parameters.

- 1 Tap **Menu** > **Restore All Defaults**. The application asks if you are sure you want to restore all defaults.
- 2 Tap **Yes**.

After several minutes, all of the default settings are restored.

## Hide Menu Items in Intermec Settings

You can hide items in the Intermec Settings menus if you do not want to have them available for other users to access. Hidden items are not saved when you back up your settings in the SmartSystems console.

On the computer, you can:

- hide menu items by tapping and holding the item, and then choosing **Hide Menu Item** from the popup list. When asked if you want to hide the menu, tap **Yes**.
- restore all hidden items in all menus, by tapping **Menu > Unhide All Items**.



**Note:** When you restore default settings in Intermec Settings, only the settings for visible items are restored to defaults. The settings for hidden menu items are not affected.

## Use Intermec Settings Remotely With SmartSystems Foundation

Your computer is SmartSystems-enabled, which lets you open Intermec Settings from the SmartSystems console to remotely configure all of your computers. For more information on SmartSystems, see [“Manage the Computer Using SmartSystems Foundation” on page 24](#).

- 1 In the SmartSystems console, select a computer and right-click.
- 2 From the menu, select **Start Intermec Settings**.
- 3 Configure the settings you need to change. As you choose parameters from the tree structure, help for each parameter appears in the upper right pane of Intermec Settings.
- 4 When you are done making changes, choose **File > Save Settings**.

For help using Intermec Settings, click **Help > Contents**. For information on all of the parameters in Intermec Settings, see the [Intermec Settings Command Reference Manual](#).

## Create and Enable Custom Profile Settings

You can create custom profile settings to ensure optimal performance of the CV61 in specific scenarios. Once you create a custom profile setting, enable it with Intermec Settings.



**Note:** For more information on how to create your own custom profiles, go to the Intermec Developer Center website at [www.intermec.com/developer/resources/CustomProfiles.aspx](http://www.intermec.com/developer/resources/CustomProfiles.aspx)

- 1 Make sure you have created a custom profile for your computer.
- 2 Tap **Start > All Programs > Intermec > Profile Settings**.
- 3 Select the profile you want to enable.

## About Network Communications

You can easily add the computer to your wireless or wired data collection network. You can connect your computer using:

- 802.11a/b/g/n radio communications.
- Bluetooth communications.
- USB and serial communications.

## Configure 802.11a/b/g/n (Wi-Fi) Radio Communications



Caution

**Make sure all components with antennas are at least 30 cm (1 ft) apart when power is applied. Failure to comply could result in equipment damage.**

The computer contains an 802.11 radio to transfer data using wireless communications and to support the TCP/IP network protocols. This section of the manual assumes that your wireless network is set up, including your access points.

By default, the 802.11 radio is enabled. If it is disabled, use the following procedure to enable the Wi-Fi radio using Intermec Settings.

- 1 From the Intermec Settings main menu, tap **Communications > 802.11 Radio > Radio Enabled**.

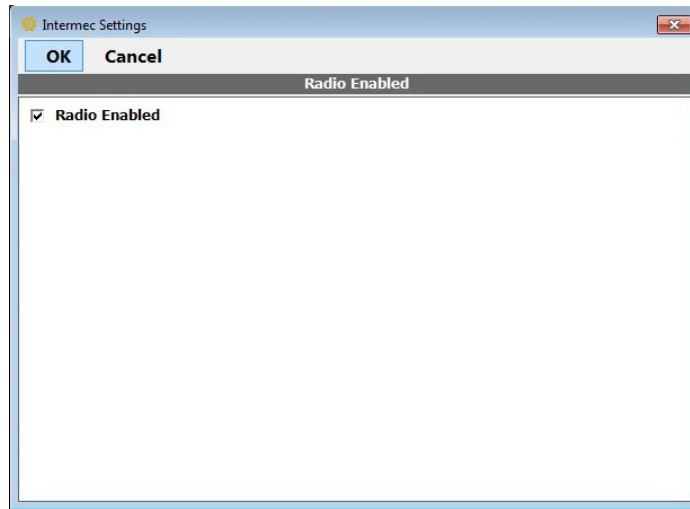

- 2 Select the **Radio Enabled** check box and tap **OK**. By default, the computer uses Microsoft security and enables DHCP.
- 3 Use Intermec Settings to configure any other parameters you need to use for communication with your network.
- 4 Configure 802.11 security. For help, see **“About Wireless Security” on page 48**.

## Configure Bluetooth Communications

Your computer is Bluetooth™-enabled, which lets you connect to other Bluetooth devices, such as scanners or printers.

The Bluetooth radio needs to be on before you can discover and connect to other Bluetooth devices. By default, the radio is turned on. You can configure Bluetooth communications using Intermec Settings or from the Start menu.

- 1 From the Intermec Settings main menu, tap **Communications > Bluetooth**.

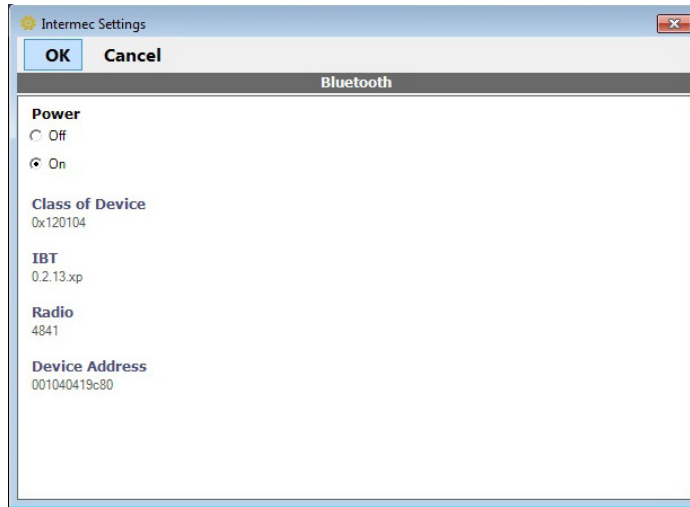

**2** Select the **On** check box.

**3** Tap **OK**.

The Bluetooth radio maintains its state through a reboot or cold boot and maintains virtual COM ports.

### Connect to a Bluetooth Printer

To configure your computer for Bluetooth wireless printing, you need to:

- create an application that opens the wireless printing COM port on your computer. For help, see the Bluetooth Resource Kit, which is part of the Intermec Developer Library (IDL), available from the Intermec website at [www.intermec.com/idl](http://www.intermec.com/idl).
- select the current wireless printer on your computer. For help, see the next procedure.



**Note:** You can also print wirelessly using Microsoft APIs with Bluetooth extensions for Winsock and Bluetooth. For help, see the Bluetooth Resource Kit documentation.

**1** Tap **Start > Control Panel**. The Control Panel appears.

**2** In the **View by:** drop-down menu, select either **Large** or **Small icons**.

**3 Tap Bluetooth Printing.**

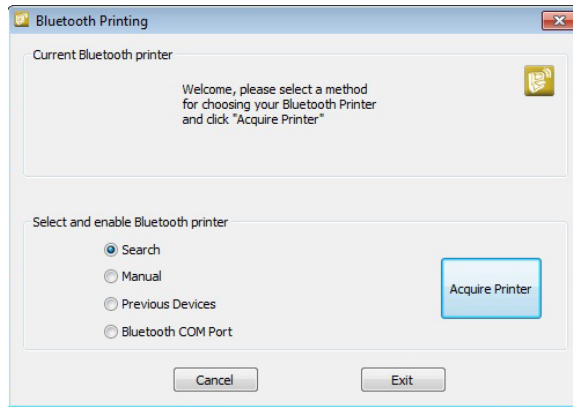

**4 Select Search, Manual, Previous Devices, Bluetooth COM Port and tap Acquire Printer.** Follow the onscreen instructions to select the current wireless printer.

**5 (Optional) Tap Print Test Page.** The printer prints out a test page.

## Create a VPN Server Connection

You can create a Virtual Private Network (VPN) connection to securely connect to servers, such as a corporate network, through the Internet. Before you can create a VPN connection, you need this information from your network administrator:

- User name
- Password
- Domain name
- TCP/IP settings
- Host name or IP address of the VPN server

After you have located this information, you can create a VPN server connection.

**1 Tap Start > Settings > Control Panel.**

**2 Double-tap Network and Dial-up Connections.**

**3 Double-tap Make New Connection.**

- 4** Double-tap either **Virtual Private Network (PPTP)** or **Virtual Private Network (L2TP)**.
- 5** Step through the screens to set up your VPN connection.

## **Connect a Scanner to the CV61**

You can connect a scanner to the CV61 through:

- USB communications
- serial communications
- Bluetooth

After you have connected a scanner, you can configure certain parameters such as bar code symbologies through the CV61. If you are using an Intermec scanner, you can configure it using EasySet™. For more information, go to [www.intermec.com/EasySet](http://www.intermec.com/EasySet).

### **Connect to a USB Scanner**

To use a USB scanner with the CV61, you need to enable HID. When you enable HID, any data handling must be programmed into the scanner since the data transmits to an active window as a keystroke message. You can program the scanner by:

- scanning the configuration bar codes from the scanner manufacturer.
- installing an application that accepts the incoming data.

### **Connect the SR30 or SR61T USB Scanner**

To connect SR30 or SR61T through USB, make sure you use the following USB cables:

- For SR61T (Gen 1), you need USB cable P/N 236-182-001.
- For SR61T (Gen 2), you need USB cable P/N 236-240-001.

- 1** From the Intermec Settings main menu, tap **Data Collection > Enable USB Scanner Auto-Detect** and select **Enable USB Scanner Auto-Detect**.
- 2** Connect the scanner to the CV61.



**3** Enable the HID profile.

- For the SR30, scan the following bar code to enable the generic HID profile:



- For the SR61T, scan the following bar code to enable the keyboard HID profile:

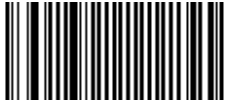

**4** Refresh Intermec Settings.

**5** Configure the scanner using Intermec Settings.

## **Connect to a Serially Tethered Scanner**

Use this procedure to connect your computer to connect a tethered scanner and enable RS-232 communications.

- 1** Connect the scanner to the COM1 or COM2 port.
- 2** From the Intermec Settings main menu, select **Tethered Scanner (COM 1 or COM 2)**.

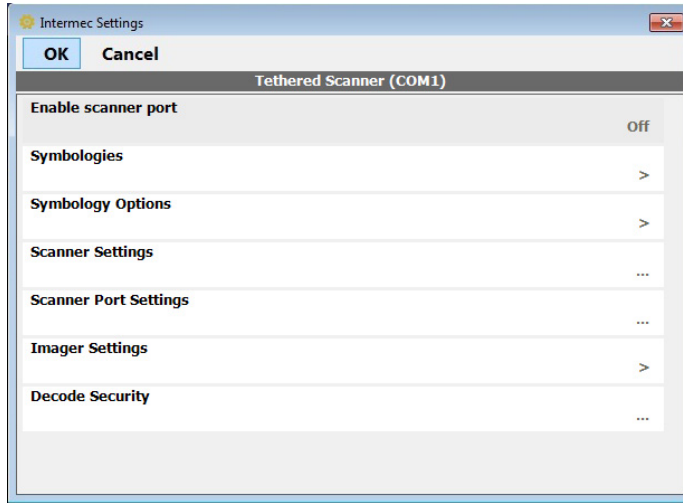

**3 Tap Scanner Settings.**

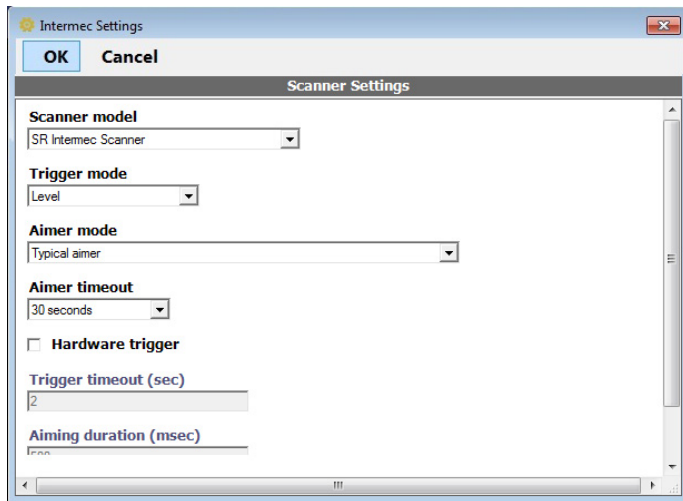

- 4 Perform one of these items based on the type of scanner you are connecting:
  - For an SR30 or SR61T scanner, tap **Scanner Settings**, select **SR Intermec Scanner**, and then tap **OK**.
  - For an ASCII scanner, tap **Scanner Settings**, select **ASCII**, and then tap **OK**. Set up the appropriate COM port settings by selecting **Scanner Port Settings**.
- 5 Tap **Enable scanner port**.
- 6 Check the **Enable scanner port** check box and tap **OK**.

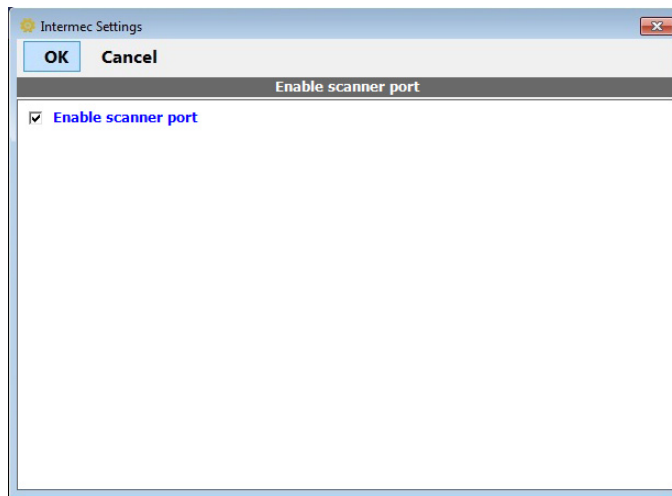

## **Connect to a Bluetooth Scanner**

You can connect the computer to an Intermec Bluetooth scanner, such as the SF51 or SR61.

- 1 Enable Bluetooth communications.
- 2 Tap **Start > Control Panel**. The Control Panel appears.
- 3 In the **View by:** drop-down menu, select either **Large** or **Small icons**.
- 4 Tap **Bluetooth Scanning**. The Bluetooth Scanning application appears.
- 5 Tap **Add Scanner**.

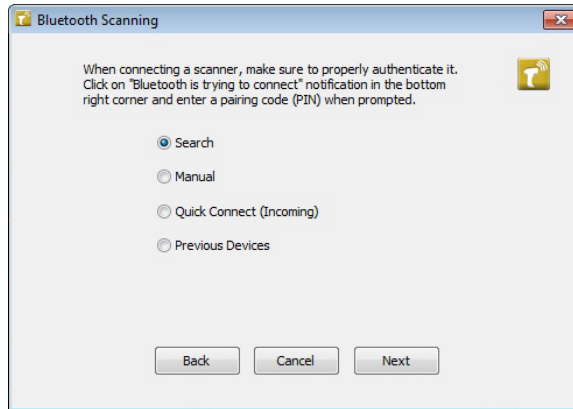

- 6 Select **Search**, **Manual**, **Quick Connect**, or **Previous Devices**. Follow the onscreen instruction to add a wireless scanner.

## About Wireless Security

The computer provides five types of security for your wireless network:

- Wi-Fi Protected Access 2 (WPA2™)
- Wi-Fi Protected Access (WPA)
- 802.1x
- WEP

This section explains how to configure wireless security on your computer. Intermec recommends that you implement WPA2 security using PSK (Personal) or 802.1X (Enterprise) key management as appropriate.

You must use either Wireless or Microsoft security to implement your security solution. For details, see the next section, **“Choose Between Microsoft and Wireless Security.”** Intermec recommends that you always implement WPA2 security using PSK (Personal) or 802.1X (Enterprise) key management.

If you are using WPA-802.1x, WPA2-802.1x, or 802.1x security, this section also assumes that your authentication server and authenticators are properly configured.



**Note:** Your security choice does not depend on your authentication server. For example, you can choose Wireless security if you use Microsoft Active Directory® to issue certificates.

## Choose Between Microsoft and Wireless Security

The computer supports both Wireless security and Microsoft security, which dynamically select wireless networks based on your preferences. The option you choose depends on your network security needs.

- If you are using the computer in a static environment that requires a high level of security, you should use Wireless security, which offers CCX v4.0 compliance, support for LEAP, EAP-FAST, TLS, and TTLS, and configuration for up to twenty profiles.

To use Wireless security, you need to select a profile. For help, see the next section, **“Select a Wireless Security Profile.”**

- If you are primarily using the computer to connect to Wi-Fi hotspots, you may want to use Microsoft security.

Microsoft security is enabled by default. If you want to use Wireless security you need to select it as your security choice. For help, see **“Select Microsoft as Your Security Choice” on page 54.**

### Select a Wireless Security Profile

You can define up to twenty profiles for Wireless security. Different profiles let your computer communicate in different networks without having to change all of your security settings. For example, you may want to set up one profile for the manufacturing floor and one for the warehouse. By default, the active profile is Profile 1.

### Select a Wireless Security Profile

Use the following procedure to select a Wireless security profile.

- 1 Start Intermec Settings. For help, see **“Start Intermec Settings” on page 33.**
- 2 Choose **Communications > 802.11 Radio > Security Choice.**
- 3 From the **Security Choice** list, select **Wireless Security.** An alert box appears telling you that you must save your settings and reboot the computer for the new security choice to take effect.

- 4 (Optional) In the **Profile Label** text box, enter a meaningful name for your profile.
- 5 Configure your security settings. For help, see the next sections.
- 6 Repeat Steps 3 through 5 for each profile you want to define.
- 7 Set an active profile by choosing it from the **Active Profile** list in the **Profile Manager**.
- 8 Save your settings.

### Configure WPA or WPA2 Enterprise (802.1x) Security With Wireless Security

Use these procedures to set WPA-802.1x or WPA2-802.1x security on your computer with Wireless security.

- 1 Make sure the communications and radio parameters on your computer are configured.
- 2 Make sure Wireless security is selected as your security choice.
- 3 Start Intermec Settings.
- 4 Choose **Communications > 802.11 Radio > Wireless Security**.
- 5 Select the profile you want to configure.
- 6 For **Association**, choose **WPA** or **WPA2**. Encryption automatically defaults to **TKIP** or **AES**, respectively.
- 7 For **8021x**, choose **TTLS**, **PEAP**, **EAP-FAST**, or **TLS**.
- 8 If you choose **TTLS**, **EAP-FAST**, or **PEAP**:
  - a For **Prompt for Credentials**, choose **Enter credentials now**.
  - b Enter a **User Name** and **User Password**.
  - c For **Validate Server Certificate**, choose **Yes**.



**Note:** The correct date must be set on your computer when you enable **Validate Server Certificate**.

- 9** If you choose TLS:
  - a** Load a user and root certificate on your computer. For help, see **“Load a Certificate” on page 59**.
  - b** Enter a **User Name** and **Subject Name**.
  - c** For **Validate Server Certificate**, choose **Yes**.

### **Configure WPA or WPA2 Personal (PSK) Security With Wireless Security**

Use the following procedure to configure WPA-PSK or WPA2-PSK with Wireless security.

- 1** Make sure the communications and radio parameters on your computer are configured.
- 2** Make sure Wireless security is selected as your security choice.
- 3** Start Intermec Settings.
- 4** Choose **Communications > 802.11 Radio > Wireless Security**.
- 5** Select the profile you want to configure.
- 6** For **Association**, choose **WPA** or **WPA2**.
- 7** For **8021x**, choose **None**.
- 8** For **Pre-Shared Key**, enter the pre-shared key or passphrase.

The pre-shared key must be a value of 32 hex pairs preceded by 0x for a total of 66 characters. The value must match the key value on the access point. The passphrase must be from 8 to 63 characters. After you enter a passphrase, the computer internally converts it to a pre-shared key. This value must match the passphrase on the authenticator.

- 9** Save your settings.

### **Configure 802.1x Security With Wireless Security**

Use the following procedure to configure 802.1x-WEP security with Wireless security. Intermec recommends that you use WPA2-802.1x instead of 802.1x-WEP if possible.

- 1** Make sure the communications and radio parameters on your computer are configured.
- 2** Make sure Wireless security is selected as your security choice.
- 3** Start Intermec Settings.
- 4** Choose **Communications > 802.11 Radio > Wireless Security**.
- 5** Select the profile you want to configure.
- 6** For **Association**, choose **Open**.
- 7** For **Encryption**, choose **WEP**.
- 8** For **8021x**, choose **TTLS, PEAP, or TLS**.
- 9** If you chose **TTLS** or **PEAP**:
  - a** Enter a **User Name**.
  - b** For **Prompt for Credentials**, choose **Enter credentials now**.
  - c** Enter a **User Password**.
  - d** For **Validate Server Certificate**, choose **Yes**.
- 10** If you choose **TLS**:
  - a** Load a user and root certificate on your computer. For help, see **“Load a Certificate” on page 59**.
  - b** For **Validate Server Certificate**, choose **Yes**.
  - c** Enter a **User Name** and **Subject Name**.
- 11** Save your settings.

### **Configure LEAP Security With Wireless Security**

After you configure the communications and radio parameters on your computer and select Wireless Security as your security choice, you can configure LEAP.

- 1** Start Intermec Settings.



- 2** Choose **Communications > 802.11 Radio > Wireless Security**.
- 3** Select the profile you want to configure.
- 4** For **8021x**, choose **LEAP**.
- 5** For **Association**, choose **Open**, **WPA**, **WPA2**, or **Network EAP**. Encryption automatically defaults to **TKIP** if you choose **WPA**, **AES** if you choose **WPA2**, and **WEP** if you choose **Open** or **Network EAP**.
- 6** For **Prompt for Credentials**, choose **Enter credentials now**.
- 7** Enter a **User Name** and **User Password**.
- 8** Save your settings.

### **Configure Static WEP Security With Wireless Security**

Use the following procedure to configure static WEP security with Wireless security. Intermec recommends that you use WPA2-PSK instead of WEP if possible.

- 1** Make sure the communications and radio parameters on your computer are configured.
- 2** Make sure Wireless Security is selected as your security choice.
- 3** Start Intermec Settings.
- 4** Choose **Communications > 802.11 Radio > Wireless Security**.
- 5** Select the profile you want to configure.
- 6** For **8021x** choose **None**.
- 7** For **Association**, choose **Open**.
- 8** For **Encryption**, choose **WEP**.
- 9** Define a value for the keys you want to use. You can define up to four keys (**Key 1** through **Key 4**).

Enter an ASCII key or a hex key that is either 5 bytes or 13 bytes long depending on the capability of the radio. Set a 5-byte value for 64-bit WEP or a 13-byte value for 128-bit WEP. Hex keys must be preceded by 0x and contain 5 or 13 hex pairs.

- 10 For **Transmit key**, choose the key you want to use for transmitting data.
- 11 Save your settings.

### Use Open (No Security) Associations with Wireless Security

Use the following procedure to configure your computer for open security using Wireless security.

- 1 Start Intermec Settings.
- 2 Choose **Communications > 802.11 Radio > Wireless Security**.
- 3 Select the active profile you are using.
- 4 For **Association**, choose **Open**.
- 5 For **Encryption**, choose **None**.
- 6 Tap **OK**. Your settings are saved.

### Select Microsoft as Your Security Choice

The default security setting is Microsoft security. If you are currently using Wireless security and want to use Microsoft Wireless Zero Configuration (WZC) security, you need to select it as your security choice. After you select Microsoft as your security choice, you will be prompted to save your settings and reset the computer for your change to take effect.

With Microsoft as your security choice, you can configure:

- WPA or WPA2 (Personal or Enterprise)
- 802.1x
- Static WEP

### Select Microsoft Security

Use the following procedure to select Microsoft security.

- 1 Start Intermec Settings. For help, see **“Start Intermec Settings” on page 33**.
- 2 Choose **Communications > 802.11 Radio > Security Choice**.

- 3** From the **Security Choice list**, select **Microsoft Security**. An alert box appears telling you that you must save your settings and reboot the computer for the new security choice to take effect.
- 4** Tap **Yes**. The computer resets and starts with Microsoft Security as the Security Choice.

### **Configure WPA or WPA2 Enterprise (802.1x) Security With Microsoft**

Use these procedures to set WPA-802.1x security on your computer with Microsoft security.

- 1** Make sure the communications and radio parameters on your computer are configured.
- 2** Tap **Start > Control Panel**. The Control Panel appears.
- 3** In the **View by:** drop-down menu, select either **Large** or **Small** icons.
- 4** Tap **Network and Sharing Center > Manage Wireless Networks**.
- 5** Select the wireless connection you want to configure and tap the **Security** tab.
- 6** For **Security type**, choose **WPA-Enterprise** or **WPA2-Enterprise** and select **TKIP** or **AES**. The Encryption type automatically defaults to **AES**.
- 7** In the **Choose a network authentication method**, choose either **LEAP**, **EAP-FAST**, **PEAP**, or **Smart Card or other certificate**.
- 8** If you choose **LEAP**:
  - a** Tap **Settings**. The Properties screen appears.
  - b** Enter a **User Name** and a **Password**. When you are finished, type in your password again in **Confirm Password**.
  - c** Tap **OK** to exit the Properties screen.
  - d** Tap **OK** again to save the Microsoft Security Settings.

- 9** If you choose **PEAP** or **EAP-FAST**:
  - a** Load a root certificate of the authentication server on your computer. For help, see **“Load a Certificate” on page 59**.
  - b** Tap **Settings**. The Properties screen appears.
  - c** Select **Validate server certificate**.
  - d** Tap the **User Credentials** tab.
  - e** Select **Use saved user name and password**, and enter a **User Name** and a **Password**. When you are finished, type in your password again in **Confirm Password**.
  - f** Tap **OK** to exit the Properties screen.
  - g** Tap **OK** to save the Microsoft Security settings.
  
- 10** If you choose **Smart Card or other certificate**:
  - a** Load a root certificate of the authentication server on your computer. For help, see **“Load a Certificate” on page 59**.
  - b** Tap **Settings**. The Properties screen appears.
  - c** Select **Validate server certificate**.
  - d** Tap **OK** to exit the Properties screen.
  - e** Tap **OK** to save the Microsoft Security settings.

### **Enable WPA or WPA2 Personal (PSK) Security With Microsoft**

Use the following procedure to enable WPA-PSK With Microsoft Security.

- 1** Make sure the communications and radio parameters on your computer are configured.
- 2** Tap **Start > Control Panel**. The Control Panel appears.
- 3** In the **View by**: drop-down menu, select either **Large** or **Small** icons.
- 4** Tap **Network and Sharing Center > Manage Wireless Networks** and select the wireless network you want to configure.

- 5** For **Security type**, choose **WPA-Personal** or **WPA2-Personal** and select **TKIP** or **AES**. The Encryption type automatically defaults to **AES**.
- 6** For **Network Security Key**, enter the pre-shared key or the passphrase.  

The pre-shared key must be a value of 32 hex pairs preceded by 0x for a total of 66 characters. The value must match the key value on the authenticator. The passphrase must be from 8 to 63 characters. After you enter a passphrase, the computer internally converts it to a pre-shared key.
- 7** Tap **OK** to save the Microsoft Security settings.

### **Configure 802.1x Security with Microsoft**

Use the following procedure to configure 802.1x security with Microsoft security. Intermec recommends that you use WPA2-802.1x instead of 802.1x-WEP if possible.

- 1** Make sure the communications and radio parameters on your computer are configured.
- 2** Tap **Start > Control Panel**. The Control Panel appears.
- 3** In the **View by:** drop-down menu, select either **Large** or **Small** icons.
- 4** Tap **Network and Sharing Center > Manage Wireless Networks** and select the wireless network you want to configure.
- 5** For **Security type**, choose **802.1x**.
- 6** In the **Choose a network authentication method**, choose either **LEAP**, **EAP-FAST**, **PEAP**, or **Smart Card or other certificate**.
- 7** If you choose **LEAP**:
  - a** Tap **Settings**. The Properties screen appears.
  - b** Enter a **User Name** and a **Password**. When you are finished, type in your password again in **Confirm Password**.
  - c** Tap **OK** to exit the Properties screen.
  - d** Tap **OK** again to save the Microsoft Security Settings.

- 8** If you choose **PEAP** or **EAP-FAST**:
  - a** Load a root certificate of the authentication server on your computer. For help, see **“Load a Certificate” on page 59**.
  - b** Tap **Settings**. The Properties screen appears.
  - c** Select **Validate server certificate**.
  - d** Tap the **User Credentials** tab.
  - e** Select **Use saved user name and password**, and enter a **User Name** and a **Password**. When you are finished, type in your password again in **Confirm Password**.
  - f** Tap **OK** to exit the Properties screen.
  - g** Tap **OK** to save the Microsoft Security settings.
  
- 9** If you choose **Smart Card or other certificate**:
  - a** Load a root certificate of the authentication server on your computer. For help, see **“Load a Certificate” on page 59**.
  - b** Tap **Settings**. The Properties screen appears.
  - c** Select **Validate server certificate**.
  - d** Tap **OK** to exit the Properties screen.
  - e** Tap **OK** to save the Microsoft Security settings.

### **Configure Static WEP Security With Microsoft**

Use the following procedure to configure static WEP security with Microsoft security. Intermec recommends that you use WPA2-PSK instead of WEP if possible.

- 1** Make sure the communications and radio parameters on your computer are configured.
- 2** Tap **Start > Control Panel**. The Control Panel appears.
- 3** In the **View by**: drop-down menu, select either **Large** or **Small** icons.
- 4** Tap **Network and Sharing Center > Manage Wireless Networks** and select the wireless network you want to configure.
- 5** In the **Security type**, choose **No authentication (Open)**.

- 6** In **Encryption type**, choose WEP.
- 7** In **Network Security Key**, enter the pre-shared key or the passphrase.
- 8** Tap **OK** to save the Microsoft Security settings.
- 9** For **Network Key Setting**, choose **Enter Key and Index**.

### **Use Open (No Security) Associations With Microsoft**

Use the following procedure to configure your computer for open security using Microsoft WZC.

- 1** Make sure the communications and radio parameters on your computer are configured.
- 2** Tap **Start > Control Panel**. The Control Panel appears.
- 3** In the **View by:** drop-down menu, select either **Large** or **Small** icons.
- 4** Tap **Network and Sharing Center > Manage Wireless Networks** and select the wireless network you want to configure.
- 5** In the **Security type**, choose **No authentication (Open)**.
- 6** In **Encryption type**, choose **None**.
- 7** Tap **OK** to save the Microsoft Security settings.

## **Load a Certificate**

To use transport layer security (TLS) with WPA or 802.1x security, you need a unique client certificate on the computer and a trusted root certificate authority (CA) certificate. Certificates are pieces of cryptographic data that guarantee a public key is associated with a private key. They contain a public key and the entity name that owns the key. Each certificate is issued by a certificate authority.

- 1** Click the **Start** button and type **certmgr.msc** into the Search box and then click the **Certificate Manager** application. If you are prompted for a password, type the password and continue.
- 2** In the menu tree, select where you want to import the certificate.
- 3** Tap **Actions > All Tasks > Import**. Follow the onscreen instruction to import a certificate to the CV61.





# 5

## Troubleshoot and Maintain the Computer

If you encounter any problems while using the computer, look in this chapter to find a possible solution. You will also find information on routine maintenance.

# Troubleshoot Your Computer

Use the troubleshooting tables in this section to fix problems with the Wi-Fi connection, 802.1x security, or general problems with operating the computer.



**Note:** If you send the computer in for service, it is your responsibility to save the computer data and configuration. Intermec is responsible only for ensuring that the hardware matches the original configuration when repairing or replacing the computer.

## Troubleshoot the Wi-Fi Connection

Use this troubleshooting table to help solve problems with your 802.11 radio connection.

### Problems With the Wi-Fi Connection

Problem	Solution
When you turn on the computer after it was suspended for a while (10 to 15 minutes or longer), it can no longer send or receive messages over the network.	Host may have deactivated or lost current terminal emulation session. In a TCP/IP direct connect network, turn off the “Keep Alive” message from host to maintain the TCP session while the computer is suspended.
The computer is connected to the network and you move to a new site to collect data. Your computer now shows you are not connected to the network.	Move closer to an access point or to a different location to reestablish communications until you reconnect with the network.
The computer appears to be connected to the network, but you cannot establish a terminal emulation session with the host computer.	There may be a problem with the host computer, or with the connection between the access point and the host computer. Check with the network administrator to make sure the host is running and allowing users to log in to the system.
The computer appears to be connected to the network, but the host computer is not receiving any information from the computer.	There may be a problem with the connection between the access point and the host computer. Check with the network administrator or use your access point user’s manual.
A network connection icon appears in the toolbar, but then disappears.	The computer may not be communicating with the intended access point. Make sure the network name matches the access point network name.  The access point may not be communicating with the server. Ensure the access point is turned on, properly configured, and has 802.1x security enabled.

## Troubleshoot 802.1x Security

Use the following table to troubleshoot problems with your 802.1x security that will prevent you from connecting to your network, such as an incorrect password.

### Problems With 802.1x Security

Problem	Solution
The computer indicates it is not authenticated.	<p>Make sure that:</p> <ul style="list-style-type: none"><li>• the User Name and Password parameters on the computer must match the user name and password on authentication server. You may need to reenter the password on both the computer and authentication server.</li><li>• on your authentication server, the user and group are allowed and the group policy is allowed to log into the server. For help, see the documentation that shipped with your authentication server software.</li><li>• the IP address and secret key for access point must match the IP address and secret key on the authentication server. You may need to reenter the IP address and secret key on both your access point and authentication server.</li><li>• the authentication server software is running on the server PC.</li></ul>
You receive a message saying “The server certificate has expired or your system date is incorrect” after you perform a clean boot on the computer.	<p>Date and time are not saved when you perform a clean boot. Reenter the date and time, and then save your changes.</p>

## Check 802.11 Network Status

If you have trouble connecting to your 802.11 wireless network:

- Make sure you have correctly set network parameters on the computer.
- Check your wireless security settings.

Follow the next procedure to verify available access points and networks, check signal strength, and view other diagnostics. If you need to contact Intermec Product Support, this information can be helpful in troubleshooting wireless network connection issues.

- 1 Tap **Start > Programs > Summit Client Utility**. The Summit Client Utility application launches.

The Main tab shows:

- the current active profile.
- network association status.

- 2 Tap the **Profile** tab to view the current active profile security settings.

- Tap the **Scan** button to view a list of available 802.11 networks. The list includes the signal strength and security information.

- 3 Tap the **Status** tab to view the current active profile status.

The Status tab shows:

- the current active profile.
- network association status.
- the IP and MAC addresses.
- the access point IP and MAC addresses.
- the DTIM and beacon period.
- the radio transmit power and signal strength information.

- 4 Tap the **Diags** tab to run a ping test to the host.

**a** In the text field, enter the IP address of the host.

**b** Tap **Start Ping**. The graph shows the amount of time it takes for the host to return the ping.

- 5 Tap the **Global** tab to view the global property values of the Wi-Fi connection.

## Troubleshoot Reading Bar Codes



Use this section to troubleshoot problems that may prevent you from being able to read a bar code with an Intermec scanner. If you cannot

find the solution in the following table, refer to your scanner user guide for more information.



**Problems with Connecting Scanners or Reading Bar Codes**

<b>Problem</b>	<b>Solution</b>
You cannot see the illumination beam or frame from the scanner when you press the <b>Scan</b> button and aim the imager at a bar code label.	<ul style="list-style-type: none"> <li>• You may be too far away from the bar code label. Try moving closer to the bar code label and scan it again.</li> <li>• You may be reading the bar code label “straight on.” Change the reading angle and try again.</li> <li>• The imager hardware trigger might be disabled in Intermec Settings. To check the setting go to Intermec Settings and select <b>Data Collection &gt; Scanner Settings</b>. Hardware trigger should be checked.</li> </ul>
When you release a <b>Scan</b> button or handle trigger, the <b>Good Read</b> light does not turn off.	The <b>Good Read</b> light remains on if you configure the computer to use continuous/edge triggering. If you configure the computer for level triggering and the <b>Good Read</b> light remains on, there may be a problem. Press one of the <b>Scan</b> buttons or pull the trigger again without scanning a bar code label. If the light is still on, contact your local Intermec representative.
The scanner will not read the bar code label.	<ul style="list-style-type: none"> <li>• Aim the scanner beam to cross the entire bar code label in one pass. Vary the scanning angle.</li> <li>• Check the quality of the bar code label. Scan a bar code label that you know will scan. Compare the two bar code labels to see if the bar code quality is too low. You may need to replace the label that you cannot scan.</li> <li>• Make sure the bar code symbology is enabled and configured correctly. Use Intermec Settings to check the symbologies. Expand <b>Data Collection &gt; Symbologies</b> beneath devices listed (scanner, virtual wedge) to check and enable symbologies, then scan the bar code label again.</li> <li>• Make sure the computer application is expecting input from a bar code. You may need to type this information instead</li> <li>• Check to see if the right scanner model is selected. To check the setting go to Intermec Settings and select <b>Data Collection &gt; Scanner Settings</b>.</li> <li>• Check to see if the scanner cable is damaged.</li> </ul>

**Problems with Connecting Scanners or Reading Bar Codes (Continued)**

<b>Problem</b>	<b>Solution</b>
The scanner does not read the bar code labels quickly, or the scanning beam seems to be faint or obscured.	The scanner window may be dirty. Clean the window with a solution of ammonia and water. Wipe dry. Do not allow abrasive material to touch the window.
When Enable Scanner Port is checked in Intermec Settings, the “COM port is busy. Another application may be using the port” error message appears.	Confirm that no other application is currently using the COM port or select another COM port for the scanner. If that does not work, try to restart the computer to see if the COM port becomes available.
The scanner does not read the bar code or is corrupted when it is enabled as an ASCII scanner.	<ul style="list-style-type: none"><li>• Check to see if the Scanner Port Settings in Intermec Settings match those settings programmed in the scan engine.</li><li>• The scanner may be in an unknown state. Reset the scanner to the factory default settings by scanning the manufacturer’s configuration bar code, and reconnect the scanner. For the SR30 or SR61T (Gen II), scan one of the following bar codes to restore factory defaults:</li></ul>
	<p><b>SR30 Scanner</b></p> 
	<p><b>SR61T (Gen II) Scanner</b></p> 
You scan a valid bar code label to enter data for your application. The data decoded by the scanner does not match the data encoded in the bar code label.	The scanner may have decoded the bar code label in a symbology other than the label’s actual symbology. Try scanning the bar code label again. Make sure you scan the entire label.
The input device attached to the computer does not work well or read bar code labels very quickly.	Set the Scanner Model command to the specific attached input device. Check enabled bar code symbologies and enable only the symbologies being used.

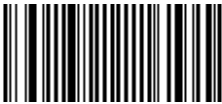
**Problems with Connecting Scanners or Reading Bar Codes (Continued)**

Problem	Solution
When connected to USB, the SR30 or SR61T (Gen II) does not show up in Intermec Settings.	<p>Make sure that:</p> <ul style="list-style-type: none"> <li>• USB Auto-detect is enabled on the CV61. For more help, see <b>“Use Intermec Settings on the Computer” on page 32.</b></li> <li>• Enable the HID profile, by scanning one of the following bar codes:</li> </ul> <p><b>SR30 Scanner</b></p>  <p><b>SR61T (Gen II) Scanner</b></p> 

**Troubleshoot Operating the Computer**

Use this section to troubleshoot problems that may prevent you from being able to operate the computer.

**Problems Operating the Computer**

Problem	Solution
You press the <b>Power</b> button and nothing happens.	Make sure that power is connected to the computer.
The computer appears to be locked up and you cannot enter data.	Restart the computer. For help, see <b>“Restart Your Computer” on page 70.</b>
You tap the screen and nothing happens.	Align your screen. For help, see <b>“Calibrate the Screen” on page 17.</b>

## Call Product Support

If you cannot find the answer to your problem in the “Troubleshooting the Computer” section, you can visit the Intermec technical knowledge base (Knowledge Central) at [intermec.custhelp.com](http://intermec.custhelp.com) to review technical information or to request technical support. If you still need help after visiting Knowledge Central, you may need to call Product Support.

To talk to an Intermec Product Support representative, call:

**1-800-755-5505**

Before you can call Intermec Product Support, make sure you have the following information ready:

- Configuration number
- Serial number
- Operating system, BIOS, and MCU versions
- Service pack version
- System component versions
- If you are using security, know the type and the full set of parameters
- If you are using Intermec Terminal Emulator (ITE), know the version and protocol. If you are not using ITE, know the language your custom application was written in and the tools you used to create it.

You can find most of the information listed above in Intermec Settings. Consult your application developer for information on your custom application.

## Find Your Configuration Number

Use the following procedure to help you find the configuration number of your computer.

- Look at the label on the side of the computer.



## Find Your System Component Versions

Use the following procedure to find your system component versions on your computer.

- From the Intermec Settings main menu, tap **Device Settings > System Component Versions**. The System Component Version screen appears.

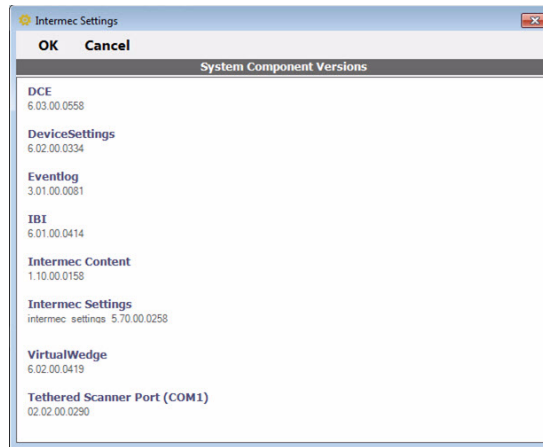

## Find Your Operating System, BIOS and MCU Versions

Use the following procedure to find your operating system, BIOS and MCU versions.

- Tap **Start > Control Panel > CV61 Properties**. The OS, BIOS, and MCU versions are shown in the System Information section of the CV61 Properties screen.



## Find Your Service Pack Version

Use the following procedure to find your Service Pack version.

- 1 Tap **Start > Control Panel**. The Control Panel appears.
- 2 In the **View by:** drop-down menu, select either **Large** or **Small** icons.
- 3 Tap **System**. The System screen appears.

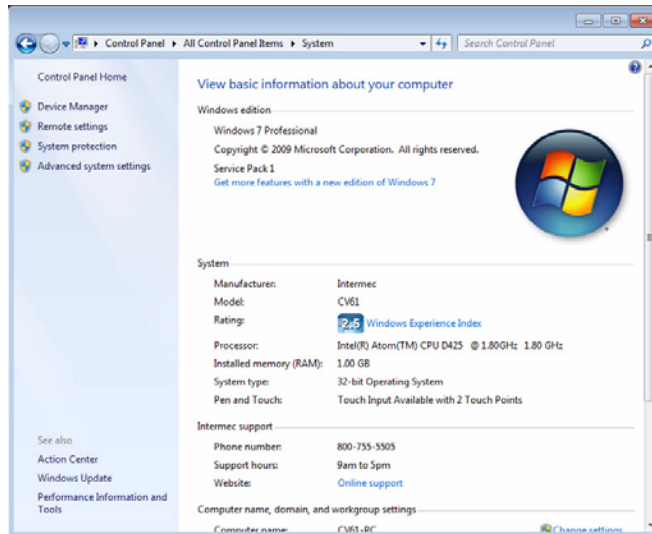

## Restart Your Computer

If the CV61 or an application locks up, you may need to restart the computer. There are two ways to restart the computer:

- Reboot
- Reset

## Reboot the Computer

If the computer seems to be locked up, try rebooting the computer.

- 1 Hold down the **Power** button until the CV61 turns off.
- 2 Press the **Power** button again to turn on the CV61.

## **Reset the Computer**

If the computer does not reboot, reset the computer. When you reset the computer, the CV61 does a full shutdown and removes power from the processor.

- 1** Using a small pointed object such as a paper clip, push in hold the **Reset** button and the **Power** button.
- 2** Release the **Reset** button while continuing to hold down the **Power** button.
- 3** When the blue Ready-to-Work indicator turns on, release the **Power** button and your computer resets.

## **Clean the Computer**

To keep the computer in good working order, you may need to clean the touch screen. Clean the touch screen as often as needed for the environment in which you are using the computer. To clean the computer, use a solution of ammonia and water.

- 1** Turn off the computer.
- 2** Dip a clean cloth towel in the ammonia solution and wring out the excess.
- 3** Wipe off the touch screen. Do not allow any abrasive material to touch these surfaces.
- 4** Wipe dry.



# 6

## Upgrade the CV61 Vehicle Mount Computer

Use this chapter to learn how to upgrade the CV61 hard drive, memory, or install an SD card.

## Upgrade the CV61

Upgrade certain components on the CV61 to increase system performance or file storage space on the CV61. The CV61 allows you to upgrade the the hard drive, memory, or install an SD card.

### Upgrade the Hard Drive

You can upgrade the CV61 hard drive to increase file storage on the CV61. To upgrade the hard drive, you need the following parts, tools, and software:

- SATA 2.5” solid state hard drive
- Small Phillips torque screwdriver

After you install the hard drive, you also need to load Microsoft Windows 7 and the Intermec system software.

- 1 Turn off the CV61.
- 2 Remove the power cable.

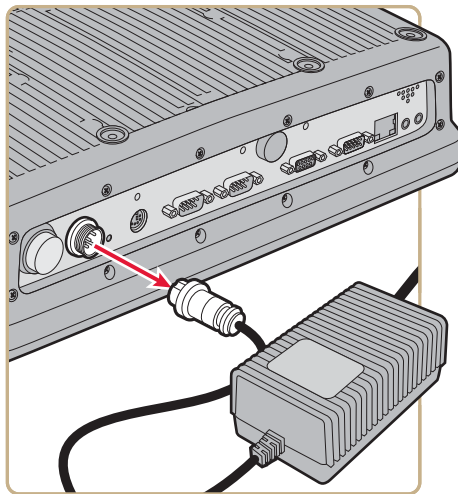

- 3 Remove the eight screws that secure the back cover to the CV61.

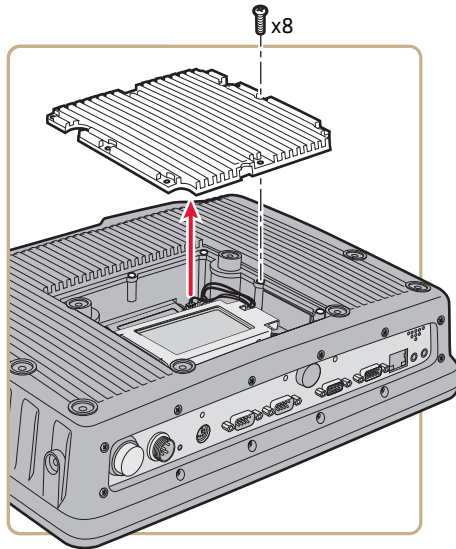

**4** Disconnect the two cables connected to the CV61.

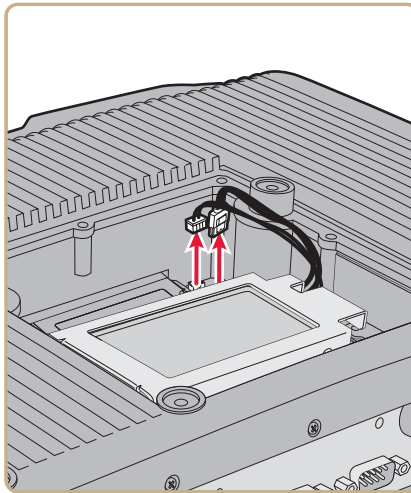

**5** Remove the four screws that secure the hard drive bracket to the CV61.

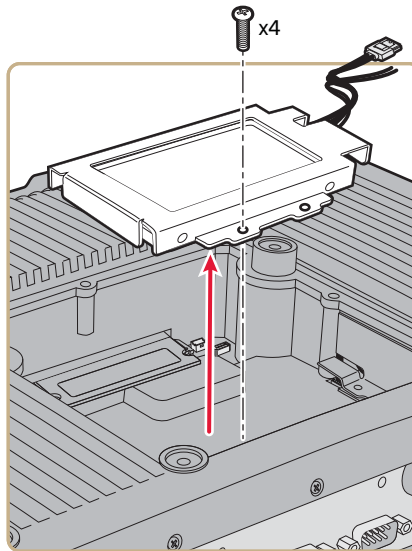

- 6** Remove the four screws that secure the hard drive to the hard drive bracket.

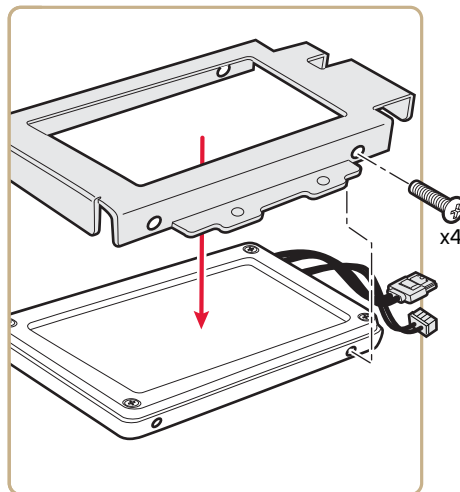

- 7** Remove the two cables that are connected to the hard drive.



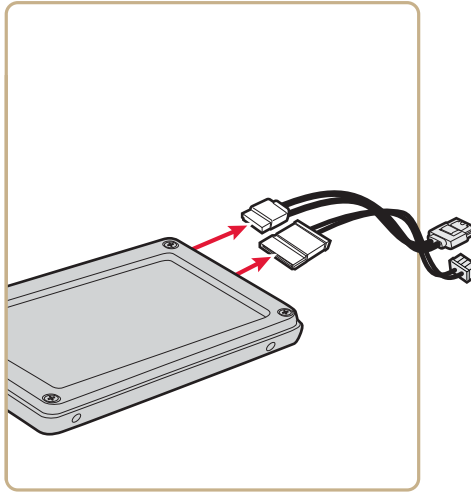

- 8 Install the new hard drive and close the CV61. Use the next illustration for the tightening sequence for the back cover. Tighten the screws to a final value of 0.73 Nm (6.5 lbf-in).

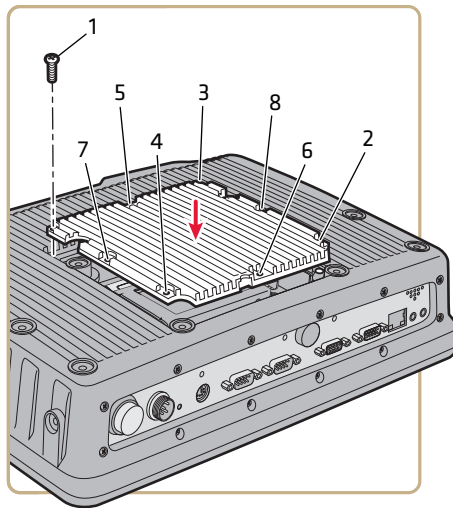

- 9 Reconnect the power cable.
- 10 Install Microsoft Windows 7.
- 11 Install the Intermec system software. For more information, see [“Update the System Software” on page 27.](#)

## **Upgrade Memory**

Upgrade the CV61 system memory to increase system performance. The CV61 supports a maximum of 3 GB of SODIMM memory. You can purchase your own SODIMM memory or purchase it from Intermec. For more information, contact your local Intermec representative. To upgrade the memory, you need the following parts and tools:

- SODIMM memory
- Small Phillips torque screwdriver

- 1** Turn off the CV61.
- 2** Remove the power cable.

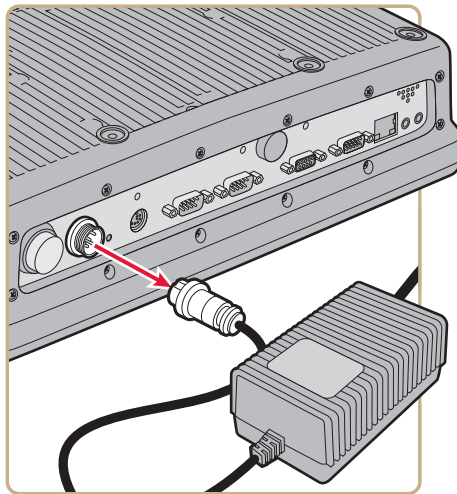

- 3** Remove the eight screws that secure the back cover to the CV61.

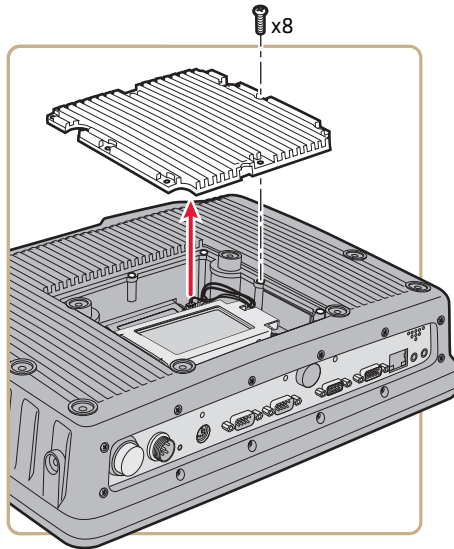

- 4** Remove the memory by pushing on the two prongs that secure the memory onto the CV61.

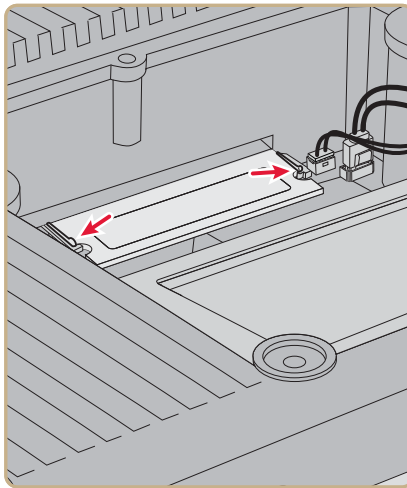

- 5** Remove the memory from the CV61.

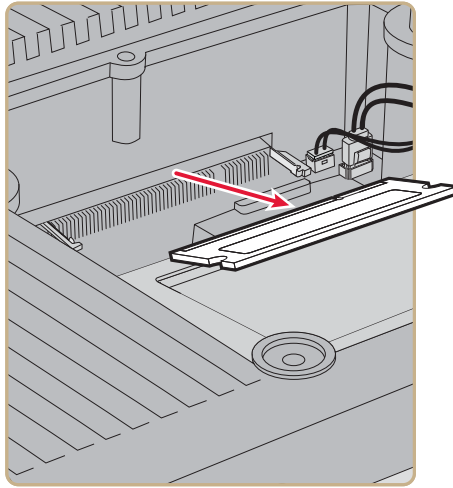

- 6** Insert the new memory and close the CV61. Use the next illustration for the tightening sequence for the back cover. Tighten the screws to a final value of 0.73 Nm (6.5 lbf-in).

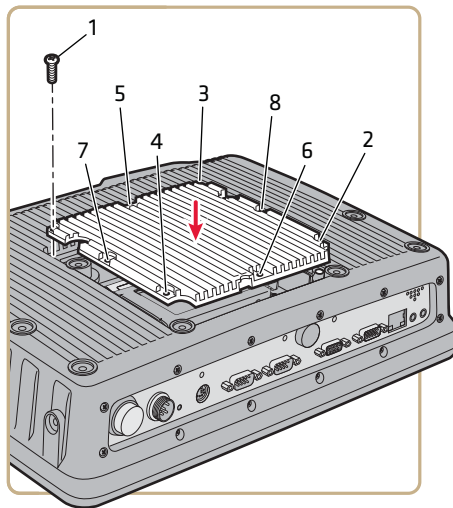

## **Install an SD Card**

You can use an SD card to increase file storage and install software. The computer supports an optional 32 GB maximum capacity SD card. To install an SD card, you need to have a small Phillips screwdriver.

- 1** Turn off the CV61.
- 2** Remove the power cord.

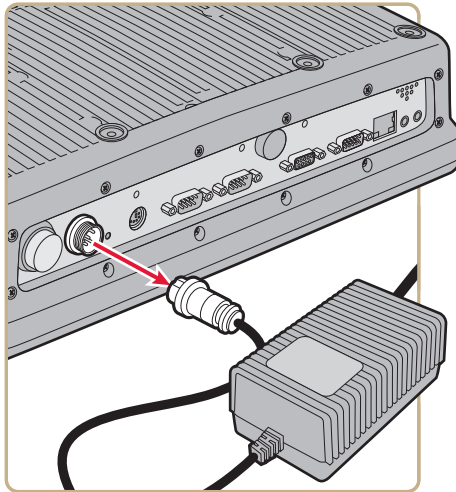

- 3** Using a small Phillips screwdriver, remove the eight screws that secure the radome cover to the CV61.

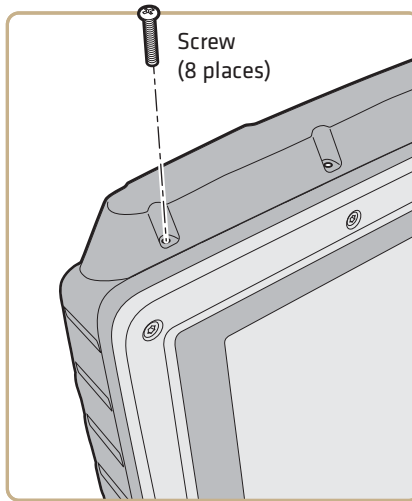

**4** Gently lift up the radome cover to expose the SD card slot.

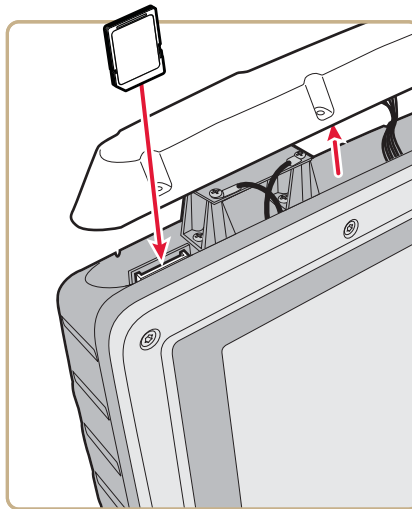

**5** Insert the SD card into place.

**6** Close the radome cover and replace the 8 screws.

**7** Reattach the power cord.

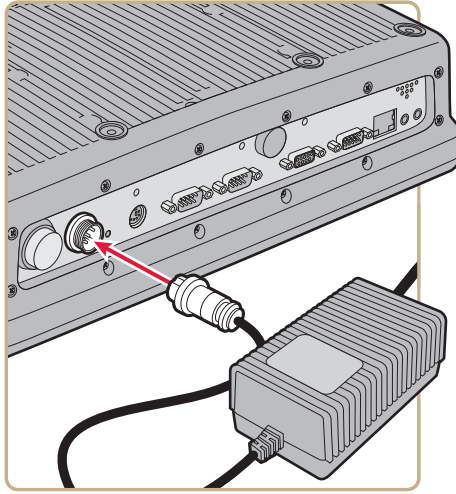

**8** Press the **Power** button. The computer turns on.





# A

## Specifications and Default Settings

# Physical and Environmental Specifications

## Physical Dimensions

CV61 dimensions	27.4 x 34.3 x 8.4 cm (10.8 x 13.5 3.3 in)
CV61 weight	5.2 kg (11.5 lbs)

## Environmental Specifications

Standard operating temperature	Non-condensing: -20 °C to 50 °C (-4 °F to 122 °F)
Extreme operating temperature	Condensing: -30 °C to 50 °C (-22 °F to 122 °F)
Storage temperature	Non-condensing: -30 °C to 60 °C (-22 °F to 140 °F)
Relative humidity	Up to 90% non-condensing at 40 °C (104 °F) with extended temperatures up to 100%
Water and dust	IP66
Vibration	MIL-STD-810F, composite wheeled vehicles

## Power and Electrical Specifications

Input power	DC input voltage: 9 to 60 VDC
External power supply	AC adapter: 90 to 240 VAC DC power supply: 15 to 96 VDC
Backup battery (CMOS)	Field replaceable, rechargeable lithium-ion battery, 30 minutes of life at -20 °C (-4 °F).
Electrical rating	--- 12 V, 4 A + 12 V, 4 A

## Hardware

Processor	Intel Atom D425 1.8 GHz
-----------	-------------------------

## Appendix A – Specifications and Default Settings

Memory	<ul style="list-style-type: none"><li>• Standard 1 GB DDR2 (Windows XP)</li><li>• Standard 2 GB DDR2 (Windows 7)</li></ul> User-upgradeable to 3 GB DDR2 memory.
Mass storage	<ul style="list-style-type: none"><li>• 16, 26, or 36 GB solid state drive (Windows XP)</li><li>• 26 or 36 GB solid state drive (Windows 7)</li></ul>
Removable storage	Up to 32 GB user-accessible SD card slot
Accelerometer	Integrated accelerometer
Interfaces	Audio port, microphone port, two USB ports, two RS-232 COM ports, a CANBUS port, and a DC power input.
Antennas	Internal antenna or optional external antenna.
Removable storage	Secure Digital
Operating system	Microsoft Windows XP or 7 Professional

## Touch Screen Specifications

XGA color display with high-durability touch screen and 500 NIT brightness; 1024 x 768 pixels; 30.7 cm (12.1 in) diagonal active area; LED backlight and ambient light sensor; field replaceable touch screen; optional heated touch screen defroster.

## Standard Communications

- 802.11a/b/g/n
- Ethernet
- Bluetooth
- USB
- Serial
- CANBUS

## Wireless LAN

Data rates	Supports all 802.11a/b/g/n data rates.
Security	WPA, WPA2, 802.1x (EAP-TLS, TTLS, LEAP, PEAP, EAP-FAST), WEP
Cisco compatibility	CCX v4 certified

## Default Configuration

The following tables list the default values of the configuration settings supported on the computer. If you restore the computer to factory default settings, the computer uses these values.

The settings are grouped by function and reflect the organization of Intermec Settings. Not all of the configuration settings are listed in this appendix. For detailed information on most of the settings, see the [\*Intermec Settings Command Reference Manual\*](#).

## Data Collection Settings

Use data collection settings to configure the Bluetooth or tethered scanner and to configure the bar codes that you want the imager to be able to read.

### **Data Collection Settings**

<b>Data Collection Setting</b>	<b>Default Value</b>
Enable Scanner	Off
BT-Configure On Connect	Overwrite with computer settings
Enable USB scanner auto-detect	Off

### **Symbology Settings**

<b>Symbology</b>	<b>Default Value</b>
AustraliaPost	Disable
Aztec	Disable
BPO	Disable
CanadaPost	Disable
Codabar	Disable
Codablock A	Disable
Codablock F	Disable
Code 11	Disable
Code 39	Enable
Code 93	Disable

**Symbology Settings (Continued)**

<b>Symbology</b>	<b>Default Value</b>
Code 128/GS1-128	Enable Code 128, GS1-128, GS1-128 identifier
DataMatrix	Enable
DutchPost	Disable
EAN/UPC	Enable UPC A, UPC E, EAN 8, EAN 13
GS1 Composite	Disable
GS1 DataBar Expanded	Disable
GS1 DataBar Limited	Disable
GS1 DataBar Omni-Directional	Disable
JapanPost	Disable
KoreaPost	Disable
Matrix 2 of 5	Disable
Maxicode	Disable
Micro PDF417	Disable
MSI	Disable
PDF417	Enable
Planet	Disable
Plessey	Disable
Postnet	Disable
QR Code	Disable
Standard 2 of 5	Disable
Telepen	Disable
TLC 39	Disable

**Symbology Option Settings**

<b>Symbology Option Settings</b>	<b>Default Value</b>
Preamble	None (Disable)
Postamble	None (Disable)
Symbology Identifier	Disable
Multicode	Disable

**Scanner Settings**

<b>Scanner Settings</b>	<b>Default Value</b>
Scanner Model	SR Intermec Scanner
Trigger Mode	Level
Aimer Mode	Typical aimer
Hardware Trigger	Enable
Trigger Timeout (sec)	2
Aiming Duration (msec)	500
Turn Off After Good Read	Enable/One-shot
Number of Good Read Beeps	One

**Scanner Port Settings**

<b>Scanner Port Settings</b>	<b>Default Value</b>
Baud Rate	57600

**Imager Settings**

<b>Scanner Port Settings</b>	<b>Default Value</b>
Predefined Modes	1D and 2D standard
Sticky Aimer LED Duration	0
Imager Decode Mode	2D imager
Ligthing Mode	Illumination LED priority
Lighting Goal	40
Top Position	0
Bottom Position	479
Aimer LEDDuration	0
Aimer Flashing	Flashing
Illumination Mode	Always on
Illumination Level	Brightest
Initial 1D Search Area	Center
Horizontal Focus Factor	Disabled
Horizontal Focus Threshold	30
Vertical Focus Factor	Disabled

**Imager Settings (Continued)**

Scanner Port Settings	Default Value
Vertical Focus Threshold	30
Direct Part Marking Mode	Disable
Damaged 1D Codes	Disable

**Decode Security Settings**

Decode Security Settings	Default Value
Consecutive Data Validation	0
Identical Consecutive Timeout	300 ms
Different Consecutive Timeout	0
Center Decoding	Disable
Center Decoding Tolerance	0

## Communications

Use communications settings to configure how the computer communicates with the network.

**Communications Settings**

Communications Setting	Default Value
Device Name	Intermec CV61

**802.11 Radio Settings**

802.11 Radio Setting	Default Value
Radio Enabled	Off
Security Choice	Microsoft Security
Microsoft Security	Disable
Active Profile	Profile 1
DHCP	Enable
DHCP Client Identifier	None
Primary DNS	None
Secondary DNS	None
Import Root Certificate	False

**802.11 Radio Settings (Continued)**

<b>802.11 Radio Setting</b>	<b>Default Value</b>
Import User Certificates	False
Radio Bands	a/b/g/n (2.4 and 5.0 GHz)
Allow Security Changes	Enabled

**Bluetooth Settings**

<b>Bluetooth Setting</b>	<b>Default Value</b>
Bluetooth Power	On

**Device Settings**

Use device settings to configure settings on the computer.

**Antenna Settings**

<b>Antenna Setting</b>	<b>Default Value</b>
Force External Antenna	Disable

**Power Management Settings**

<b>Power Management Setting</b>	<b>Default Value</b>
COM1 5 Volt Power	Enable
COM2 5 Volt Power	Enable

**PS/2 Settings**

<b>Antenna Setting</b>	<b>Default Value</b>
PS/2 Port Access	Enable

**Heater Settings**

<b>Screen Setting</b>	<b>Default Value</b>
Screen Heater	Disabled



### Screen Settings

Screen Settings	Default Value
Screen Brightness	100
Adaptive Brightness	Disable
Screen Blanking On Motion	Disable
Screen On Delay After Motion Stops (sec)	1.0

## Core Messaging Service Settings

Use core messaging service settings to configure the message routers between client and server software applications.

### Core Messaging Service Settings

Core Messaging Service Setting	Default Value
Associated Server IP	Null
Broadcast Name	INTERMEC
Port	62241
Keep Alive Ping Interval	30 Seconds

## RFID Settings

Use RFID settings to enable the RFID service.

### RFID Settings

RFID Settings	Default Value
Enable RFID Service	Off

## Virtual Wedge Settings

Use virtual wedge settings to configure the virtual wedge.

### Virtual Wedge Settings

Virtual Wedge Settings	Default Value
Virtual Wedge	Enable
Virtual Wedge Method	Adapt to Application

**Virtual Wedge Settings (Continued)**

<b>Virtual Wedge Settings</b>	<b>Default Value</b>
Barcode Scanner Wedge	
Barcode Scanner Grid	Null
Label Encoding	1252(D)-ANSI Win3.1 US
RFID Reader Wedge	
Read Command	READ REPORT = DIRECT
User-Defined Read Command	Read
Date (YYYY-MM-DD)	Disable
Time (HH_MM_SS)	Disable
Tag Separator	SP (Space)
End of Message	CRKF (Return Line Feed)
RFID Reader Grid	Null

**Common Lockdown Service Settings**

Use common lockdown service settings to configure the common lockdown service.

**Common Lockdown ServiceSetting**

<b>Common Lockdown Service Settings</b>	<b>Default Value</b>
Port	7243
Maximum Client Connections	10
Enable Server	Enable
Enable Windows Key	Disable
Enable Task Manager Key	Disable
Enable Task Switcher Key	Disable
Enable Windows Security Dialog Key	Disable
Enable Closing Application Key	Disable
Enable Minimize Key	Disable
Enable New Session Key	Disable
Enable Server	Enable
Enable Windows Key	Disable

## Device Monitor Settings

Use device monitor settings to configure how the computer monitors the network.

### Device Health Controls

Device Health Setting	Default Value
Enable Health Data Collection	On
Enable Blue Light (LED)	Off for Ready-to-Work
Set Rule File Location	\\SmartSystems\HealthRules.txt
Set Data Refresh Periods	
Asset Msg Send Period	0 seconds
System Device Health	90 seconds
Network Device Health	45 seconds
Printer	0

## Port Pin Assignments

Use this section to learn about the ports pin assignments on the CV61.

### COM 1 and COM 2 Ports

By default, Pin 9 is configured to provide + 5 V for an external bar code scanner, or it can be configured to provide RI.

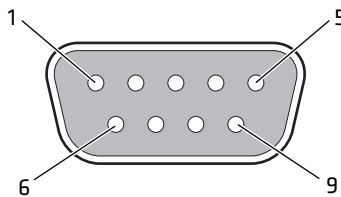

### COM 1 and COM 2 Port Pin Assignments

Pin	Signal	Description
1	DCD	Data carrier detect (input)
2	RXD	Receive data (input)
3	TXD	Transmit data (output)
4	DTR	Data terminal ready (output)

**COM 1 and COM 2 Port Pin Assignments**

Pin	Signal	Description
5	GND	Signal/power ground
6	DSR	Data set ready (input)
7	RTS	Request to send (output)
8	CTS	Clear to send (input)
9	+5 VDC or RI	Bar code scanner power (500 mA max) or Ring indicator (input)
Shell	CGND	Chassis ground

**USB Port**

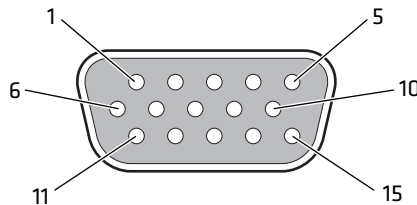

**USB Ports**

Pin	Signal	Description
1	-	
2	-	
3	-	
4	-	
5	-	
6	USB1_D-	USB client data signal
7	USB1_D+	USB client data signal
8	USB1_VBUS	USB host 1 (5 V output power)
9	GND	Common ground
10	GND11USB2_VBUS	USB host 2 (5 V output power)
11	GND	Common ground
12	USB2_D-	USB client data signal
13	USB2_D+	USB client data signal

**USB Ports (Continued)**

Pin	Signal	Description
14	GND	Common ground
15	GND	Common ground

**CANBUS Port**

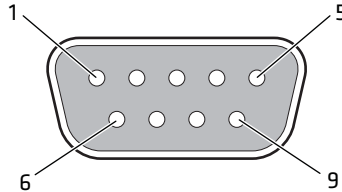

**CANBUS Port**

Pin	Signal	Description
1	-	No connect
2	CAN_L	CAN_L bus line dominant low
3	GND	Ground
4	-	No connect
5	GND	Ground
6	GND	Ground
7	CAN_H	CAN_H bus line dominant high
8	-	No connect
9	CAN V+	Optional CAN external power supply

**Power Connector**

If you are connecting to an external DC/DC supply, you must apply power to DC+. If you are connecting to 10 to 60 V vehicle power, connect power to V In+

## Appendix A – Specifications and Default Settings

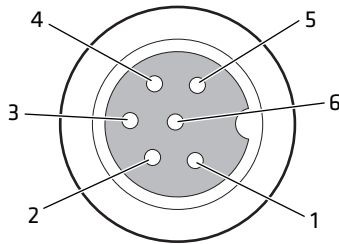

### Power Supply Connector

Pin	Signal	Description
1	GND	Chassis ground
2	DC+	12 V, 4 A from external DC supply
3	DC-/V In-	Input -
4	HTR-	Input -
5	HTR+	12 V, 4 A from external DC supply (only required if the CV61 has optional heated defroster)
6	V In+	10 to 60 V (Input to internal DC/DC power supply)

# B

## ScanNGo Wi-Fi Configuration Bar Codes

You can use the ScanNGo Wi-Fi configuration bar codes to quickly configure the 802.11 radio in your computer.

## Radio Configuration Bar Codes

Use the following ScanNGo bar codes to enable the 802.11 radio and set the defaults for either Wireless security or Microsoft security. After you scan the bar codes, you will still need to use Intermec Settings or another configuration program to set network-specific settings on your computer and to configure the wireless security.



**Note:** If you are using Microsoft security, you can only use the 1D configuration bar codes.

The following ScanNGo bar codes were created using SmartSystems Foundation. For more information on SmartSystems Foundation, see [“Manage the Computer Using SmartSystems Foundation” on page 24.](#)

## 2D Configuration Bar Codes

You can configure the computer with a 2D imager.

- 1 Scan the appropriate bar code from the table and wait for the program to start.
- 2 Follow any instructions on the device.

### 2D Imager Radio Configuration Bar Codes

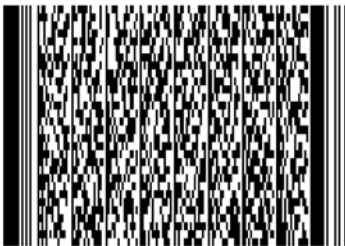
When You Want To:	Scan This Bar Code
<ul style="list-style-type: none"><li>• Set all communication settings to defaults (Wi-Fi, WWAN if applicable)</li><li>• Enable Wi-Fi - set Wireless security to defaults</li></ul>	



## **1D Configuration Bar Codes**

You can configure the computer with a 1D imager.

- 1** Scan the **START HERE** bar code from the table and wait for the program to start.
- 2** Scan the **1/9** bar code.
- 3** Scan the rest of the bar codes in any order.
- 4** Follow any instructions on the device.

## Appendix B – ScanNGo Wi-Fi Configuration Bar Codes

### 1D Imager Radio Configuration Bar Codes

#### When You Want To:

#### Scan This Bar Code

- Set all communication settings to defaults (Wi-Fi, WWAN if applicable)
- Enable Wi-Fi - set Wireless security to defaults



START HERE



1/9



2/9



3/9



4/9



5/9

**When You Want To: Scan This Bar Code**

- Set all communication settings to defaults (Wi-Fi, WWAN if applicable)
- Enable Wi-Fi - set Wireless security to defaults



6/9



7/9



8/9



9/9

## Appendix B – ScanNGo Wi-Fi Configuration Bar Codes

### When You Want To:

### Scan This Bar Code

- Set all communication settings to defaults (Wi-Fi, WWAN if applicable)
- Enable Wi-Fi - set Microsoft security to defaults



START HERE



1/9



2/9



3/9



4/9



5/9



6/9

**When You Want To: Scan This Bar Code**

- Set all communication settings to defaults (Wi-Fi, WWAN if applicable)
- Enable Wi-Fi - set Microsoft security defaults



7/9

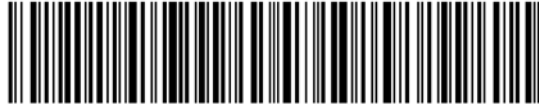

8/9

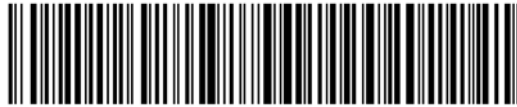

9/9

---

***Appendix B – ScanNGo Wi-Fi Configuration Bar Codes***





Worldwide Headquarters  
6001 36th Avenue West  
Everett, Washington 98203  
U.S.A.

tel 425.348.2600

fax 425.355.9551

[www.intermec.com](http://www.intermec.com)

© 2012 Intermec Technologies  
Corporation. All rights reserved.

## CV61 Vehicle Mount Computer (Windows 7) User Guide



P/N 935-043-001