

# CN4

## Mobile Computer

CN4, CN4e, CN4NI



**User's Manual**

Intermec Technologies Corporation

Worldwide Headquarters  
6001 36th Ave.W.  
Everett, WA 98203  
U.S.A.

[www.intermec.com](http://www.intermec.com)

The information contained herein is provided solely for the purpose of allowing customers to operate and service Intermec-manufactured equipment and is not to be released, reproduced, or used for any other purpose without written permission of Intermec Technologies Corporation.

Information and specifications contained in this document are subject to change without prior notice and do not represent a commitment on the part of Intermec Technologies Corporation.

© 2009-2011 by Intermec Technologies Corporation. All rights reserved.

The word Intermec, the Intermec logo, Norand, ArciTech, Beverage Routebook, CrossBar, dcBrowser, Duratherm, EasyADC, EasyCoder, EasySet, Fingerprint, i-gistics, INCA (under license), Intellitag, Intellitag Gen2, JANUS, LabelShop, MobileLAN, Picolink, Ready-to-Work, RoutePower, Sabre, ScanPlus, ShopScan, Smart Mobile Computing, SmartSystems, TE 2000, Trakker Antares, and Vista Powered are either trademarks or registered trademarks of Intermec Technologies Corporation.

There are U.S. and foreign patents as well as U.S. and foreign patents pending.

Wi-Fi is a registered certification mark of the Wi-Fi Alliance.

Microsoft, Windows, and the Windows logo are registered trademarks of Microsoft Corporation in the United States and/or other countries.

Bluetooth is a trademark of Bluetooth SIG, Inc., U.S.A.

This product includes software developed by the OpenSSL Project for use in the OpenSSL Toolkit ([www.openssl.org](http://www.openssl.org)).

This product includes cryptographic software written by Eric Young (EAY@cryptsoft.com).

miniSD is a trademark of the SD Card Association. The SD logo is a trademark.

This product uses Regex++, Index software during its operational phases. The owner of Regex++ has granted use of the software to anyone provided such use is accompanied by the following copyright and permission notice:

Regex++, Index. (Version 3.31, 16th Dec 2001)

Copyright © 1998-2001 Dr John Maddock

Permission to use, copy, modify, distribute and sell this software and its documentation for any purpose is hereby granted without fee, provided that the above copyright notice appear in all copies and that both that copyright notice and this permission notice appear in supporting documentation. Dr John Maddock makes no representations about the suitability of this software for any purpose. It is provided "as is" without express or implied warranty.

## Document Change Record

This page records changes to this document. The document was originally released as Revision 001.

Version Number	Date	Description of Change
003	10/2011	Revised to add information on sending feedback about this manual and to correct the clean booting procedure.
002	08/2010	Revised to support the CN4NI Mobile Computer and the EA11 area imager.



# Contents

Before You Begin.....	ix
Safety Information.....	ix
Global Services and Support.....	ix
Warranty Information.....	ix
Web Support.....	x
Send Feedback.....	x
Telephone Support.....	x
Service Location Support.....	x
Who Should Read This Manual.....	xi
Related Documents.....	xi
Patent Information.....	xii

<b>1 Using the CN4.....</b>	<b>1</b>
Introducing the CN4 Series Mobile Computers.....	2
What's New in This Release.....	3
Using the Battery.....	3
Charging the Battery.....	4
Changing the Battery.....	4
Checking the Battery Status.....	6
Maximizing Battery Life.....	8
Managing Power on the CN4.....	8
Choosing a Power Management Profile.....	9
Customizing Power Timeouts.....	10
Using the Keypad.....	12
Using the Color-Coded Keys.....	13
Entering Characters on the Alphabetic and QWERTY Keypads.....	13
Using Caps Lock.....	13
Entering Characters on the Numeric Keypads.....	14
Using the Green Key Lock Feature.....	14
Using the Windows Mobile Application Keys.....	14
Using the Power Button.....	15
Understanding the Audio Features.....	15
Using the CN4 as a Cell Phone.....	15
Adjusting the Volume of the Rear Speaker.....	17
Enabling the Vibrate Mode.....	18
Using the Screen.....	18

## Contents

Using the Stylus . . . . .	19
Understanding the Screen Icons . . . . .	20
Aligning the Touch Screen . . . . .	21
Configuring the Backlight . . . . .	22
Understanding the Status LEDs . . . . .	23
Using the Imager . . . . .	24
Reading Bar Codes . . . . .	25
Improving Imager Performance . . . . .	28
Capturing Images . . . . .	29
Using the Image Capture Application . . . . .	29
Configuring the Image Capture Application . . . . .	30
Copying Images to Your Desktop PC . . . . .	31
Integrating Image Capture Into Your Application . . . . .	32
Capturing Signatures . . . . .	32
Capturing Documents (EA21 only) . . . . .	32
Using the Color Camera . . . . .	35
Installing a miniSD or SIM Card . . . . .	37
Setting Up GPS on Your CN4 . . . . .	39
Using the GPSID Installed on the CN4 . . . . .	39
Learning About Additional GPS Options for the CN4 . . . . .	42
<b>2 Connecting and Configuring the CN4 . . . . .</b>	<b>43</b>
Managing the CN4 With SmartSystems Foundation . . . . .	44
Connecting to a PC . . . . .	45
Configuring the Phone . . . . .	46
Activating the CDMA Phone . . . . .	46
Activating the GSM/EDGE Phone . . . . .	48
Making a Phone Call . . . . .	48
Turning the Phone On and Off . . . . .	48
Configuring the CN4 Parameters . . . . .	48
Using Intermec Settings Remotely With SmartSystems Foundation . . . . .	49
Using Intermec Settings Directly On the CN4 . . . . .	50
Hiding Menu Items in Intermec Settings . . . . .	52
Configuring the CN4 for Your Network . . . . .	52
Configuring 802.11b/g Radio Communications . . . . .	53

Configuring Ethernet Communications .....	53
Configuring Bluetooth Communications .....	54
Connecting to a Bluetooth Scanner.....	55
Connecting to a Bluetooth Printer.....	56
Connecting to a Bluetooth Audio Device.....	57
Using Serial and USB Communications.....	57
Managing Network Connections With iConnect.....	58
Configuring Wireless Security.....	59
Choosing Between Microsoft and Funk Security.....	60
Selecting a Funk Security Profile .....	61
Selecting Microsoft as Your Security Choice.....	65
Loading a Certificate .....	68
Disabling Security .....	70

### **3 Developing and Installing Applications .....** 71

Developing Applications for the CN4.....	72
Packaging Your Application .....	72
Choosing a Target Location for the Application .....	72
Installing Applications on the CN4.....	73
Installing Applications Using SmartSystems Foundation Console.....	73
Installing Applications Using Microsoft ActiveSync.....	74
Installing Applications Using a Storage Card .....	74
Installing Applications Using the FTP Server .....	75
Launching an Application Automatically .....	75
Integrating Image Capture.....	76
Calling Image Capture From Your Application .....	76
Creating and Editing the Image Capture XML File.....	77
Image Capture XML Example.....	80
Freeing Up Virtual Memory for Applications .....	80
Upgrading the System Software .....	82
Locating Upgrade Files .....	83
Upgrading the CN4 Using SmartSystems Foundation.....	84
Upgrading the CN4 Using a miniSD Card.....	85

<b>4</b>	<b>Troubleshooting and Maintaining the CN4</b>	87
	Calling Product Support	88
	Troubleshooting the CN4	89
	Checking 802.11 Network Status	94
	Resetting the CN4	97
	Warm Booting the CN4	98
	Cold Booting the CN4	98
	Clean Booting the CN4	99
	Cleaning the CN4	100
<b>A</b>	<b>Specifications and Default Settings</b>	101
	Physical and Environmental Specifications	102
	Accessories	109
	Default Settings	110
	Data Collection	110
	Communications	113
	GPS	115
	Device Monitor	115
	Core Messaging Service	115
<b>B</b>	<b>Keypads and Keystrokes</b>	117
	Standard Characters	118
	Other Available Characters	121
	Language-Specific Characters	123
<b>I</b>	<b>Index</b>	127



# Before You Begin

This section provides you with safety information, technical support information, and sources for additional product information.

## Safety Information

Your safety is extremely important. Read and follow all warnings and cautions in this document before handling and operating Intermec equipment. You can be seriously injured, and equipment and data can be damaged if you do not follow the safety warnings and cautions.

This section explains how to identify and understand warnings, cautions, and notes that are in this document.



**A warning alerts you of an operating procedure, practice, condition, or statement that must be strictly observed to avoid death or serious injury to the persons working on the equipment.**



**A caution alerts you to an operating procedure, practice, condition, or statement that must be strictly observed to prevent equipment damage or destruction, or corruption or loss of data.**



**Note:** Notes either provide extra information about a topic or contain special instructions for handling a particular condition or set of circumstances.

## Global Services and Support

### Warranty Information

To understand the warranty for your Intermec product, visit the Intermec website at [www.intermec.com](http://www.intermec.com) and click **Support > Returns and Repairs > Warranty**.

Disclaimer of warranties: The sample code included in this document is presented for reference only. The code does not necessarily represent complete, tested programs. The code is provided “as is with all faults.” All warranties are expressly disclaimed, including the implied warranties of merchantability and fitness for a particular purpose.

## **Web Support**

Visit the Intermec website at [www.intermec.com](http://www.intermec.com) to download our current manuals (in PDF).

Visit the Intermec technical knowledge base (Knowledge Central) at [www.intermec.com](http://www.intermec.com) and click **Support > Knowledge Central** to review technical information or to request technical support for your Intermec product.

## **Send Feedback**

Your feedback is crucial to the continual improvement of our documentation. To provide feedback about this manual, please contact the Intermec Technical Communications department directly at [TechnicalCommunications@intermec.com](mailto:TechnicalCommunications@intermec.com).

## **Telephone Support**

In the U.S.A. and Canada, call **1-800-755-5505**.

Outside the U.S.A. and Canada, contact your local Intermec representative. To search for your local representative, from the Intermec website, click **About Us > Contact Us**.

## **Service Location Support**

For the most current listing of service locations, click **Support > Returns and Repairs > Repair Locations**.

For technical support in South Korea, use the after service locations listed below:

### **AWOO Systems**

102-1304 SK Ventium

522 Dangjung-dong

Gunpo-si, Gyeonggi-do Korea, South 435-776

Contact: Mr. Sinbum Kang

Telephone: +82-31-436-1191

Email: [mjyun@awoo.co.kr](mailto:mjyun@awoo.co.kr)

### **IN Information System PTD LTD**

6th Floor

Daegu Venture Center Bldg 95

Shinchun 3 Dong

Donggu, Daegu City, Korea

Email: [jmyou@idif.co.kr](mailto:jmyou@idif.co.kr) or [korlim@gw.idif.co.kr](mailto:korlim@gw.idif.co.kr)

## Who Should Read This Manual

This manual is written for the person who is responsible for installing, configuring, and maintaining the CN4, CN4e, and CN4NI Mobile Computers.

This manual provides you with information about the features of the mobile computer and how to install, configure, operate, maintain, and troubleshoot it.

Before you work with the mobile computer, you should be familiar with your network and general networking terms, such as IP address.

## Related Documents

This list contains related Intermec documents and their part numbers.

- *Intermec Settings Command Reference Manual*
- *Intermec Developer Library (IDL) Resource Kit Developer's Guide*

The Intermec website at [www.intermec.com](http://www.intermec.com) contains our documents (as PDF files) that you can download for free.

### To download documents

- 1** Visit the Intermec website at [www.intermec.com](http://www.intermec.com).
- 2** Click the **Products** tab.
- 3** Using the **Products** menu, navigate to your product page. For example, to find the CN4 computer product page, click **Computers > Handheld Computers > CN4**.
- 4** Click the **Manuals** tab.

If your product does not have its own product page, click **Support > Manuals**. Use the **Product Category**, the **Product Family**, and **Product** to help find your documentation.

## **Patent Information**

Product is covered by one or more of the following patents:

4882476; 4894523; 4953113; 4961043; 4970379; 4988852; 5019699;  
5021642; 5038024; 5081343; 5095197; 5144119; 5144121; 5182441;  
5187355; 5187356; 5195183; 5216233; 5216550; 5195183; 5195183;  
5218191; 5227614; 5233172; 5241488; 5243602; 5258606; 5278487;  
5288985; 5308966; 5322991; 5331136; 5331580; 5342210; 5349678;  
5359185; 5371858; 5373478; 5389770; 5397885; 5410141; 5414251;  
5416463; 5442167; 5464972; 5468947; 5468950; 5477044; 5486689;  
5488575; 5500516; 5502297; 5504367; 5508599; 5514858; 5530619;  
5534684; 5536924; 5539191; 5541419; 5548108; 5550362; 5550364;  
5565669; 5567925; 5568645; 5572007; 5576529; 5592512; 5594230;  
5598007; 5608578; 5616909; 5619027; 5627360; 5640001; 5657317;  
5659431; 5671436; 5672860; 5684290; 5719678; 5729003; 5742041;  
5761219; 5764798; 5777308; 5777309; 5777310; 5786583; 5793604;  
5798509; 5798513; 5804805; 5805807; 5811776; 5811777; 5818027;  
5821523; 5828052; 5831819; 5834753; 5834749; 5837987; 5841121;  
5842070; 5844222; 5854478; 5862267; 5869840; 5873070; 5877486;  
5878395; 5883492; 5883493; 5886338; 5889386; 5892971; 5895906;  
5898162; 5902987; 5902988; 5912452; 5923022; 5936224; 5949056;  
5969321; 5969326; 5969328; 5979768; 5986435; 5987192; 5987499;  
5992750; 6003775; 6012640; 6016960; 6018597; 6024289; 6034379;  
6036093; 6039252; 6064763; 6075340; 6095422; 6097839; 6102289;  
6102295; 6109528; 6119941; 6128414; 6138915; 6149061; 6149063;  
6152370; 6155490; 6158661; 6164542; 6164545; 6173893; 6195053;  
6234393; 6234395; 6244512; 6249008; 6328214; 6330975; 6345765;  
6356949; 6367699; 6375075; 6375076; 6375344; 6431451; 6435411;  
6484944; 6488209; 6497368; 6532152; 6538413; 6539422; 6621942;  
6641046; 6681994; 6687403; 6688523; 6732930

There may be other U.S. and foreign patents pending.

# 1

## Using the CN4

This chapter introduces the CN4 and CN4e Mobile Computers with Windows® Mobile® 6.1. It also contains hardware and software configuration information to assist you in getting the most out of your computer. This chapter contains these topics:

- **Introducing the CN4 Series Mobile Computers**
- **What's New in This Release**
- **Using the Battery**
- **Using the Keypad**
- **Understanding the Audio Features**
- **Using the Screen**
- **Understanding the Status LEDs**
- **Using the Imager**
- **Using the Color Camera**
- **Installing a miniSD or SIM Card**
- **Setting Up GPS on Your CN4**

# Introducing the CN4 Series Mobile Computers

The Intermec CN4 and CN4e Mobile Computers are ergonomically designed mobile computers built on the Microsoft Windows Mobile® 6.1 operating system. They are lightweight, easy-to-use, and run most software developed for the Windows Mobile platform, including standalone, client-server, and browser-based applications.

The CN4 and CN4e support similar feature sets. The CN4e offers extended environmental specifications and larger keys for data intensive applications. The CN4NI (both the CN4 and CN4e) is certified for use in non-incendive environments. Throughout this manual, all versions of the computer are referred to as the CN4 Series Mobile Computer or CN4.



## ***CN4e and CN4 Mobile Computers***



The CN4 Series Mobile Computer with an IEEE 802.11b/g radio installed is Wi-Fi® certified for interoperability with other 802.11b/g wireless LAN devices.

Standard CN4 features include:

- GPS, 802.11b/g, Bluetooth®, and WWAN radios. For WWAN, choose from one of these options:
  - UMTS/HSDPA
  - CDMA/1xRTT/EV-DO Rev A
- IP64 seal rating and 1.8 m (6 ft) drop specification
- a 2-megapixel color camera with LED flash, EA21 Area Imager, or EA11 Area Imager.
- 128 MB RAM.
- a numeric, QWERTY (CN4), or alphabetic (CN4e) keypad.

Use this manual to understand how to use the features and options available on the CN4. For information about the Windows Mobile applications installed on the CN4, see the online help.

## What’s New in This Release

This version of the manual has been updated to:

- add information on sending feedback about this manual. For more information, see **“Send Feedback” on page x**.
- correct the clean booting procedure. For more information, see **“Clean Booting the CN4” on page 99**.

## Using the Battery

The CN4 uses the following Intermec batteries as a main power source. All have been certified to meet the IEEE 1725 standard for rechargeable batteries.

### ***Standard and Extended Batteries for CN4 and CN4e***

<b>Computer</b>	<b>Uses This Standard Battery</b>	<b>Uses This Extended Battery</b>
CN4	AB8 or AB15	AB9 or AB16
CN4e	N/A	AB9 or AB16
CN4NI	N/A	AB28

Standard batteries have 8.1 Watt hours capacity and extended batteries have 14.8 Watt hours capacity. You must fully charge the battery before you can use the CN4.



**The battery used in this device may present a fire or chemical burn hazard if it is mistreated. Do not disassemble it, heat it above 100 °C (212 °F) or incinerate it.**



**If you fail to replace the low battery immediately, you may lose important data or applications.**

**If the CN4 is not on external power and you remove the battery pack, you need to install a charged battery within 5 minutes, or the CN4 resets and you could lose data.**

Dispose of used batteries promptly. Keep away from children. Contact your Intermec representative for replacement batteries.

## Charging the Battery

The battery pack should be fully charged before you use the CN4 for the first time. If battery temperatures are within the battery charging range of 0 °C to 40 °C (32 °F to 104 °F), the standard battery pack takes up to four hours to charge. The extended battery pack takes up to five hours.

The battery is fully charged when the battery status LED shows a steady green.

### To charge the battery

- Insert the battery into a quad battery charger, a single dock, or a multidock, or attach external power to the CN4 with the battery installed. For information on these accessories, see **“Accessories” on page 109**.

## Changing the Battery

When you remove the battery from the CN4, an internal super capacitor maintains your status, memory, and real-time clock for up to five minutes. To maximize this time, suspend the CN4 before changing the battery.



**To change the battery**

- 1 Press and release the **Power** button to suspend the CN4.
- 2 Unsnap the top end of the handstrap.

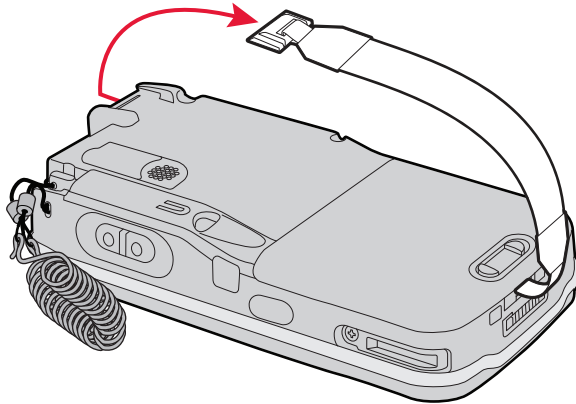

- 3 Slide the tab on the battery to release it from the CN4.



**Note:** For the CN4NI, use a Phillips screwdriver to loosen and tighten the battery set screw.

- 4 Place the end of the battery into the battery compartment as shown in the next illustration, and press down on the other end of the battery until it clicks into place.

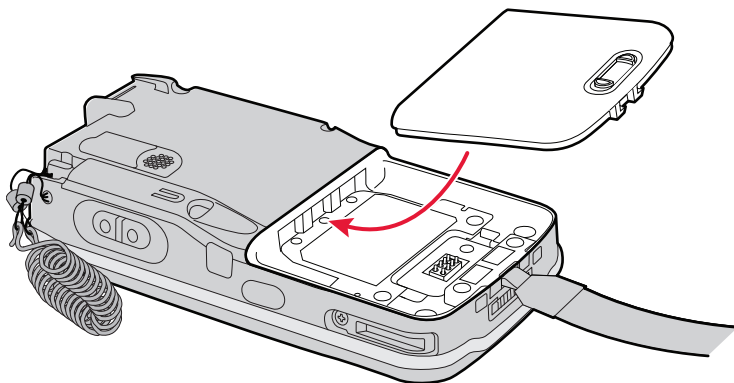

- 5 Snap the top of the handstrap into place.

## Checking the Battery Status

A quick way to check the status of your battery is to look at the battery icon on the CN4 Status bar.

### Battery Icon Status

Icon	Status
	Battery is fully charged.
	Battery has a medium charge. You should be able to work for several more hours before changing batteries.
	Battery is low. You need to replace or charge the battery soon.
	Battery is critically low. You need to replace or charge the battery now.
	Battery is charging.

The Battery Status LED indicates the charging status.

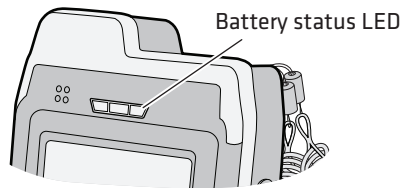

### Understanding the Battery Status LED

Battery Status	Description
Steady green	The battery is more than 95% charged and CN4 is on a charger.
Blinking red	The battery is low. CN4 goes into Suspend mode. Charge or replace the battery.
Steady red and the CN4 is attached to external power.	The battery is charging.
Steady red and the CN4 is <b>not</b> attached to external power.	The CN4 firmware is not working properly. Cold boot the CN4 as described in “ <a href="#">Cold Booting the CN4</a> ” on page 98.

**Understanding the Battery Status LED (continued)**

Battery Status	Description
Steady amber	The battery is missing or is unable to charge. If the battery will not charge, it may be because the temperature is outside of the charging range, or you may be using a battery not approved by Intermec. You need to use one of the battery models specified in <b>“Standard and Extended Batteries for CN4 and CN4e” on page 3.</b>
Off	The CN4 is not on external power and the battery is operating normally.

You can also check the battery status by using the Power application.

**To check the battery status**

- Tap **Start** > **Settings** > the **System** tab > **Power** > the **Battery** tab.

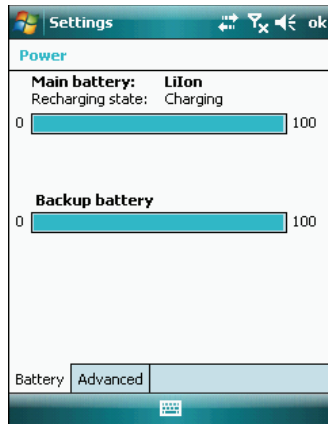

## Maximizing Battery Life

Batteries are chemical devices. If the batteries are left sitting on a shelf for long periods of time outside the CN4, the batteries slowly discharge, eventually to zero if left uncharged. The battery chemistry resists normal degradation if you store the battery in a charger as opposed to leaving the battery in a discharged state. See the following table for tips you can do to maximize the life of your battery.

### **Battery Conservation Tips**

<b>When You Want To:</b>	<b>Do This to Save Battery Power:</b>
Operate the CN4 and the Low Battery status icon appears or the Battery light comes on.	Press the <b>Power</b> button to turn off the CN4. Remove the battery and insert another fully charged battery within five minutes or you may lose data. Or, you can connect the CN4 to an external power source.
Stop using the CN4 for five minutes or longer.	Make sure the low battery icon is not on the screen and that the Battery light is not turned on. Press the <b>Power</b> button to turn off the CN4.
Store the CN4 for more than a day.	If you are storing the CN4 for a few days, like over the weekend, install the charged battery or attach the CN4 to a power source.  If you are storing the CN4 for longer, remove and charge the battery, then store both the battery and the CN4 in a cool location.  If the battery in storage is not used in several months, you should recharge the battery to keep it at its performance peak.
Store the battery outside the CN4.	Store the batteries in a charger.

## Managing Power on the CN4

Several factors determine the life of your battery such as extreme temperatures, input devices, and your usage.

By default, the CN4 goes into a lower power mode or turns off after two minutes of inactivity. Press the **Power** button to resume activity at any time.

There are several ways you can manage power:

- You can set the amount of time that the screen stays on, or the amount of time the CN4 stays on after the screen turns off. For help, see **“Customizing Power Timeouts” on page 10.**
- You can change the amount of time the screen backlight stays on. For help, see **“Configuring the Backlight” on page 22.**
- You can choose a Power Management Profile to manage power based on the way you use your CN4. Each profile turns off the screen and the CN4 at preset times, and maintains data connections differently. For help, see the next section.

## Choosing a Power Management Profile

- 1 Tap **Start** > **Settings** > the **System** tab > **Power Profiler**.

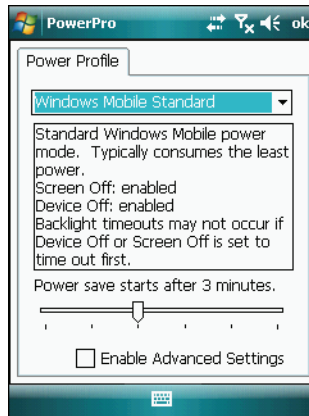

- 2 From the drop-down list, select **Windows Mobile Classic**, **Windows Mobile Standard**, or **Windows Mobile Phone**. If the list is grayed out, uncheck the **Enable Advanced Settings** check box.

For more information, see the next section, **“About Power Management Profiles.”**

- 3 Tap **ok** in the upper right corner to save your changes.

Power Profiler also provides advanced settings that allow you to fine-tune the power usage. You can choose to have the **Power** button turn off the screen or turn off the device.



**Note:** You can also configure all of the settings in Power Profiler using Intermec Settings. For help with Intermec Settings, see “[Configuring the CN4 Parameters](#)” on page 48.

### About Power Management Profiles

Use the Windows Mobile Standard profile (default) for applications that power off infrequently, such as inventory management or terminal emulation. If the CN4 does not have any activity, the screen turns off, but WAN, LAN, or Bluetooth radio connections are maintained in a low power state. If there continues to be no activity, the CN4 eventually turns off LAN and Bluetooth data connections and goes into Suspend mode. The CN4 maintains its WAN connection during Suspend mode, and still receives incoming phone calls or other data. To wake up the CN4 and restore other connections, press the **Power** or **Scan** button.

Use the Windows Mobile Classic profile for systems that batch data and upload it several times a day. This profile does not support constant data connections over LAN or Bluetooth. It can only maintain data connections when the CN4 is on and all peripherals are enabled. If the screen is off, you do not have any LAN, or Bluetooth connections, but the CN4 maintains its WAN connection and still receives incoming phone calls or other data. To wake up the CN4 and restore other connections, press the **Power** or **Scan** button.

Use the Windows Mobile Phone profile when you have a system that requires network wake-up or you need the CN4 to always be connected to the network. Although the connections are maintained at a low power mode, this setting typically consumes the most power. If the screen turns off, the radios continue to maintain the network connections. To turn the screen back on, press the **Power** or **Scan** button.

### Customizing Power Timeouts



**Note:** When you set timeout values this way, you override values used by the Power Management Profiles.

## To customize power timeout values

- 1 Tap **Start** > **Settings** > **System** tab > **Power Profiler**.
- 2 In the **Power Profile** tab, tap **Enable Advanced Settings**.
- 3 Tap the **Screen Settings** tab to change screen timeout values:
  - Check the **Enable Screen Off** check box to be able to turn off the screen independently of the CN4.
  - To change the amount of inactivity time before the screen turns off, move the **Battery Power** or **External Power** sliders.  
For battery power, choose from 1 to 6 minutes. For external power, choose from 1, 2, 5, 10, or 15 minutes, or disable this feature.
- 4 Tap the **Device Settings** tab to change power timeout values:
  - Check the **Enable Device Off** check box to be able to turn off the CN4 by pressing the **Power** button. This feature is enabled by default unless you are using the Windows Mobile Phone power profile.
  - To change the amount of inactivity time before the CN4 turns off and goes into Suspend mode, move the **Battery Power** or **External Power** sliders.  
For battery power, choose from 1 to 6 minutes. For external power, choose from 1, 2, 5, 10, or 15 minutes, or disable this feature.
- 5 Tap the **Power Button** tab to change what happens when you press the **Power** button:
  - Choose **Turn off the Device** to put the CN4 in Suspend mode when you press the **Power** button. In Suspend mode, data connections (except for WAN) are turned off. To restore data connections, you need to press the **Power** button to wake up the CN4.
  - Choose **Turn off the Screen** if you want to leave the CN4 on but with the screen turned off when you press the **Power** button. This mode uses more power than Suspend mode, but maintains all data connections. Press the **Power** button to turn the screen on.

# Using the Keypad

The CN4 comes with either a QWERTY keypad or a numeric keypad. The CN4e comes with either an alphabetic keypad or a numeric keypad.

The QWERTY and alphabetic keypads are for applications that require mainly alphabetic data. The numeric keypads are for applications requiring mainly numeric data.



**CN4 QWERTY Keypad**

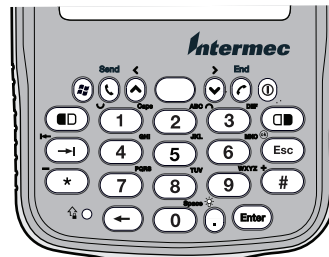

**CN4 Numeric Keypad**

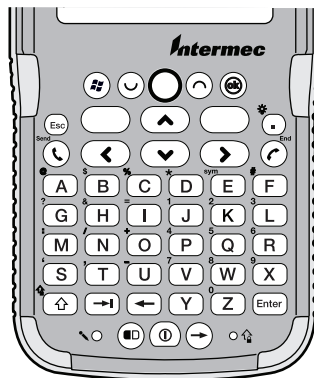

**CN4e Alphabetic Keypad**

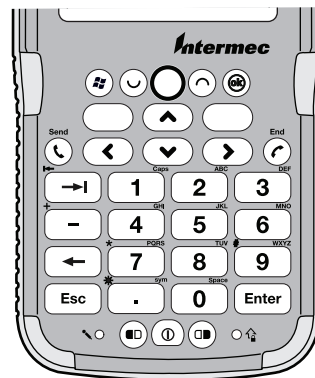



**CN4e Numeric Keypad**















**Note:** Some available characters are not printed on the keypad overlays. For a complete list of available characters, see Appendix B, “Keypads and Keystrokes.”



## Using the Color-Coded Keys

All keypads include color-coded modifier keys for characters, symbols, and functions printed on the keypad overlay. The numeric keypads include an orange  modifier key and a green  modifier key. The alphanumeric keypads include an orange  modifier key.

### Using the Color-Coded Keys



To Do This	Press	Example
Use an orange character or function printed above a key.	 key (LED illuminates) and then the key with the character or function printed above it (LED turns off).	On the QWERTY keypad, press  and then  to type the @ character.
Use a green character or function printed above a key.	 key (LED illuminates) and then the key with the character or function printed above it (LED turns off).	On the numeric keypad, press  and then  to type a lowercase a.
Lock the orange or green key to stay on.	 or  twice.	On the numeric keypad, press  twice and the green LED illuminates and stays on.
Unlock a green or orange key.	 or  once.	Press the  or  once to unlock the key and turn off the LED.



## Entering Characters on the Alphabetic and QWERTY Keypads

Press the key for the character to type that character. To type a character or access a function printed on the keypad overlay, press  and then press the key for the character or function you want.

To type a single uppercase letter on the QWERTY and alphabetic keypads, press  and then the letter key.

### Using Caps Lock

To type only uppercase letters, press   to enable the Caps Lock feature. Press the same key sequence to disable Caps Lock. When Caps Lock is enabled, the Caps Lock LED turns on.

While Caps Lock is enabled, you can still type orange characters by pressing  and then the key for that character. Caps Lock remains enabled until you press  .











## Entering Characters on the Numeric Keypads

To type a character or access a function printed in orange on the keypad overlay, press  and then press the key for the character or function you want.





To type a character or access a function printed in green on the keypad overlay, press  and then press the key for the character or function you want.



Above most of the keys, there is a grouping of three or four letters. To type letters above a key, press  and then press the key one to four times depending on the placement of the letter.

For example, above  there are the letters “ABC”:



- To type “c”, press    .
- To type “C,” press   and then press    .

### Using the Green Key Lock Feature

Press   to enable the Green Key Lock feature. When the green  key is locked, you can type letters without pressing  before each number key.

- While the green key is locked, press  to toggle between only uppercase and lowercase letters.
- To turn off the Green Key Lock, press .



**Note:** If you turn off the Green Key Lock, you may need to press   to return to lowercase letters if uppercase letters were previously enabled.

## Using the Windows Mobile Application Keys







On the CN4e keypads, the keys closest to the screen are the standard Windows Mobile application keys.



**Windows Mobile Application Keys on CN4e Keypad**

On the CN4 keypads, you can access the Windows Mobile application keys as follows:

### **Windows Mobile Application Keys on CN4 Keypads**

To Use	On Numeric Keypad, Press	On QWERTY Keypad, Press
Softkey 1	 1	 W
Softkey 2	 3	 O
“ok”	 	 P

## Using the Power Button

When you press the Power  button, you put the CN4 into Suspend mode. In this lower power mode, the CN4 continues to supply power to all memory, but turns off power to most hardware such as the display. This feature is designed to prolong battery life.



**Note:** If you do not have a SIM card installed, it may take up to 30 seconds for the CN4 to suspend.

## Understanding the Audio Features

The CN4 audio features include two speakers, a microphone, an external volume control, and multiple software tools for configuring the volume of sounds.

## Using the CN4 as a Cell Phone



**Note:** For more information on using the phone, see [“Configuring the Phone” on page 46](#).

When you use the CN4 as a cell phone, use the microphone and a front speaker for talking on the phone.

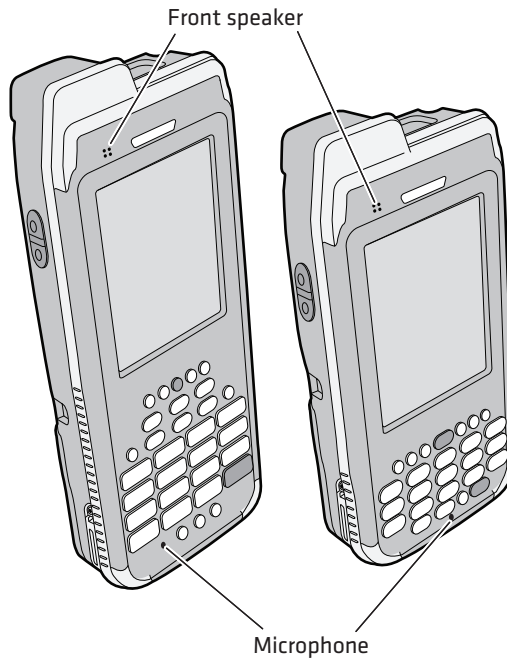

### **Microphone and Front Speaker Locations**

#### **To adjust the volume of the front speaker**

- 1 Tap the Volume icon (  ) at the top of the screen.
- 2 In the Volume adjust box, tap **On**.
- 3 Move the volume slider for the phone.

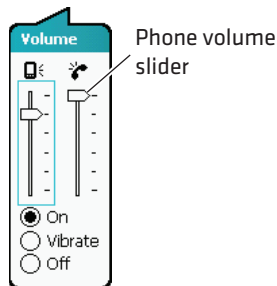

## Adjusting the Volume of the Rear Speaker

The rear speaker is used for all other computer audio. You can set the volume to off, very low, low, medium (default), high, and very high.

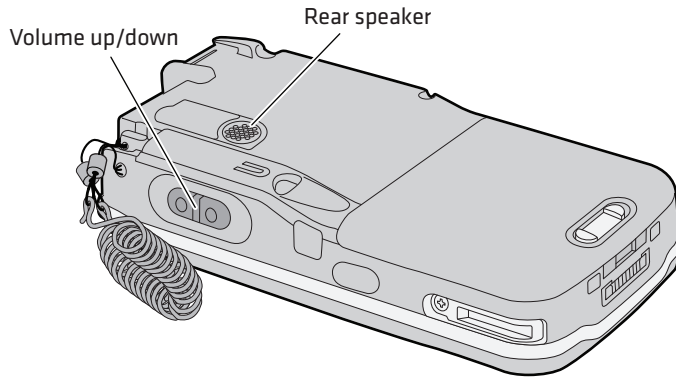

### Location of the Rear Speaker and Volume Control

Choose one of these methods to change the rear speaker volume.

- Use the Volume slider to change the rear speaker volume:
  - a Tap the Volume icon (  ) at the top of the screen.
  - b In the Volume adjust box, tap **On**.
  - c Use your stylus to move the volume slider for the rear speaker.

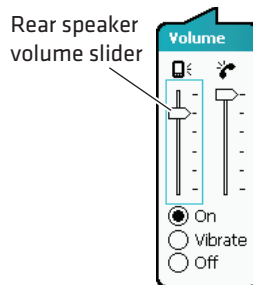

- Press the side volume button to change the volume:
  - Press the top to turn the volume up.
  - Press the bottom to turn the volume down.
- Use Intermec Settings to set the default volume. For help, see **“Configuring the CN4 Parameters” on page 48.**

## Enabling the Vibrate Mode

You can enable the vibrate mode when audio is difficult to hear, such as in a high noise environment. When enabled, the CN4 vibrates when the scanner performs a good read or when the phone receives a call.

### To enable the vibrate feature

- 1 Tap the Volume icon (  ) at the top of the screen.
- 2 Tap **Vibrate**.

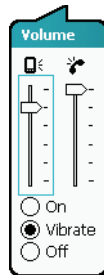

**Note:** The Volume icon in the Navigation bar changes to look like a vibrating CN4 (  ) when the Vibrate feature is enabled.

## Using the Screen

The CN4 has a 3.5" diagonal, 240 x 320 pixel (QVGA) transreflective TFT-LCD 64K color display.

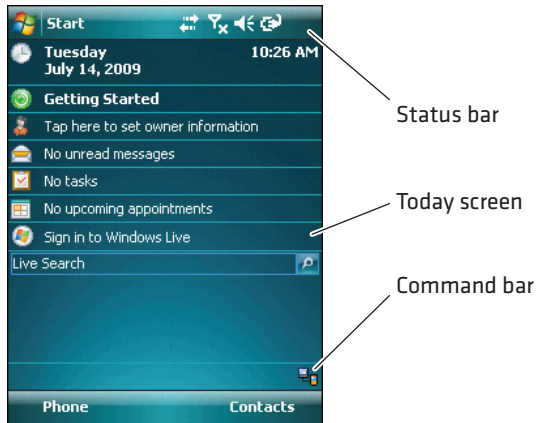

- The Status bar displays the Start flag, connectivity icons, the Volume icon, and the time and next appointment.
- The Today screen displays shortcuts to some of the applications installed on the CN4 and important information for the day.

The Command bar displays the onscreen keyboard icon, Windows Mobile 6.1 links, and icons to any applications that are running, but are hidden from view.



### The Windows Mobile Today Screen

To turn the screen backlight on and off:

- For all keypads except the QWERTY keypad, press  .
- For the QWERTY keypad, press .



**Note:** To help conserve battery power, you can change the amount of time that the screen backlight stays on. For help, see [“Configuring the Backlight” on page 22](#).

## Using the Stylus

The CN4 has a stylus for selecting items and entering information on the touch screen.











### Functions You Can Perform With the Stylus

Action	Description
Tap	Touch the screen once with the stylus to select options, open or close applications, or launch menus from the Command bar.
Drag	Hold the stylus on the screen and drag across the screen to select text and images.
Tap and hold	Tap and hold the stylus on an item to see a menu of actions available for that item. On the pop-up menu that appears, tap the action you want to perform.

## Understanding the Screen Icons

The screen icons on the Status bar and Command bar indicate battery charge levels, network connections, and so on. Some standard Microsoft icons are included in this table.

### **Computer Screen Icons**

<b>Icon</b>	<b>Description</b>
	The battery is full.
	The battery is low. You need to replace or charge the battery very soon.
	The CN4 is on external power and the battery is charging.
	The volume is turned off. To turn the volume back on, tap this icon and choose your setting.
	The computer is connected to the network.
	The computer is not connected to the network.
	The 802.11b/g radio is connected to the wireless network.
	The phone is connected to your WAN network.
	The computer is connected through the USB port to your desktop PC.
	The iConnect application icon. Tap it to set up Ethernet or Wireless settings.
	No SIM card is installed.



## Aligning the Touch Screen











If the touch screen does not respond when you tap it with the stylus, you may need to calibrate the screen.

### To align the touch screen

- 1 Tap **Start** > **Settings** > the **Systems** tab > **Screen**.
- 2 Tap **Align Screen** and follow the instructions to align the screen.
- 3 Tap **ok**.

If the touch screen is so out of alignment that you cannot open the Start menu, you may need to align the screen menu using only the keypad, or as a last resort you can perform a clean boot. For more information about performing a clean boot, see “**Clean Booting the CN4**” on page 99.

### To align the touch screen using the keypad

- 1 Press  (upper left corner of the keypad).
- 2 Press  to select **Settings** and then press .
- 3 Press  or  until the Personal tab is selected.
- 4 On the CN4e, press  to select the System tab.  
On the CN4, press   to select the System tab.
- 5 Use the arrow keys to choose **Screen** and then press .
- 6 Tab to **Align Screen** and press .
- 7 Follow the instructions to align the screen.
- 8 Tap **ok**.

## Configuring the Backlight

By default, the CN4 goes into Screen Off mode when there is no activity on the computer. Screen Off mode turns off the backlight and display. Press a key or tap the screen to resume activity.

It is possible to override the backlight settings by changing the power management settings. For more information on configuring power management, see [“Managing Power on the CN4” on page 8](#).

### To configure the backlight

- 1 Tap **Start** > **Settings** > the **System** tab > **Backlight** > the **Battery Power** tab.
- 2 With **Turn off backlight if device is not used for** checked, select the timeout value (10 seconds, 30 seconds, or 1 to 5 minutes).

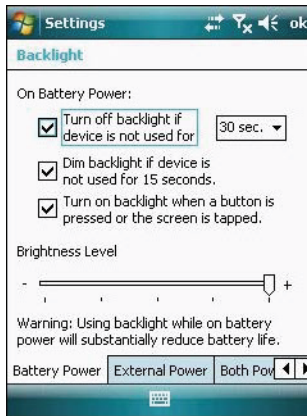

You can also use Intermec Settings to configure the backlight settings. For more information, see [“Configuring the CN4 Parameters” on page 48](#).

# Understanding the Status LEDs

The status LEDs above the display show the following information:

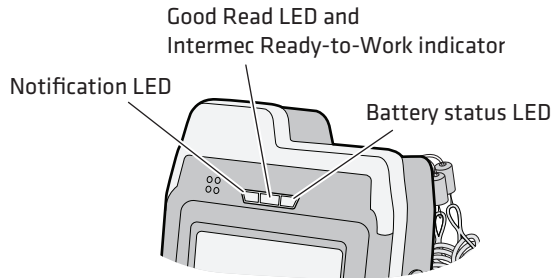

## Understanding the LEDs

LED	Color	Description
Notification	Orange	The CN4 is notifying you of a pending alarm or message. For more information on the Battery Status LED, see <a href="#">“Understanding the Battery Status LED” on page 6.</a>
Good Read	Green	The CN4 has successfully decoded a bar code.
Ready-to-Work™ indicator	Blue	The CN4 is suspending or resuming with the display turned off. Intermec Terminal Emulator (ITE) is running and connected to the host.
	Blinking blue	ITE is running but not connected to the host.
	Off	ITE is not installed or not running.

The Ready-to-Work indicator (blue light) is for SmartSystems Foundation, which is part of a wireless network using all Intermec devices. Selected application software programs may also use the indicator for other purposes. For more information, see [“Managing the CN4 With SmartSystems Foundation” on page 44.](#)



**Note:** The blue light may stay on for up to 30 seconds, but will usually turn off after less than 10 seconds. During this time, do not toggle the CN4 on or off and do not remove the battery. If the computer seems to behave erratically, first try warm booting and then cold booting the CN4 as described in [“Resetting the CN4” on page 97.](#)

# Using the Imager

The CN4 has two available area imagers: EA11 and EA21. The EA11 provides a “laser-like” aimer and is optimized for a scan-intensive environment. The EA21 provides a laser framer and is optimized for document imaging. Both area imagers can scan 1D and 2D bar codes.

The following table shows the minimum bar code size supported by each imager.

### **Minimum Bar Code Sizes**

<b>Imager</b>	<b>1D</b>	<b>2D</b>
EA11	5 mil	5 mil
EA21	6 mil	10 mil

The area imager in the CN4 can perform multiple tasks:

- Reading bar codes, including 1D, 2D, and composite symbologies and postal codes. For more information, see the next section, “Reading Bar Codes.”
- Capturing images. Use the imager like a digital camera to take high-quality, grayscale grayscale pictures. For more information, see **“Capturing Images” on page 29.**
- Capturing signatures. Use the imager to “photograph” signatures on business forms, or to capture onscreen signatures or line drawings. For more information, see **“Capturing Signatures” on page 32.**
- EA21 only: Document imaging of full business forms such as bills of lading or invoices. For more information, see **“Capturing Documents (EA21 only)” on page 32.**

## Reading Bar Codes

The CN4 imager can scan 1D and 2D bar code symbologies, composite symbologies, and postal codes. You can position the CN4 in almost any orientation to scan a bar code label.

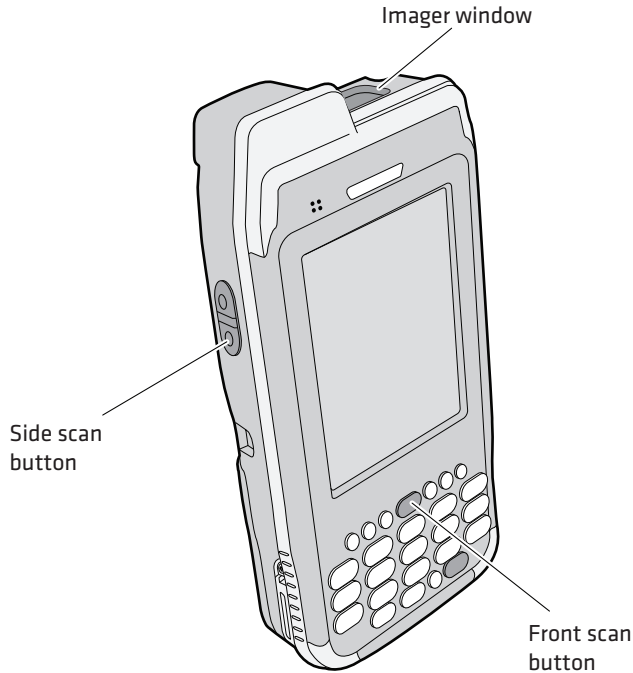

**CN4 Imager and Scan Button Locations**

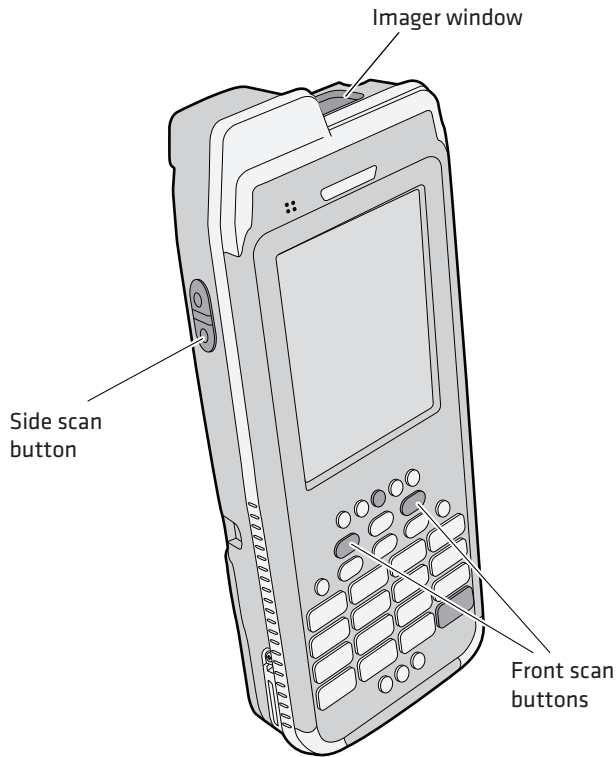

***CN4e Imager and Scan Button Locations***

**To read bar codes**

- 1** Press the **Power** button to turn on the CN4, point the scanner window a few inches from the bar code label, and hold steady.
- 2** Press and hold the **Scan** button. A laser pointer, illumination beam, and aiming frame turn on.

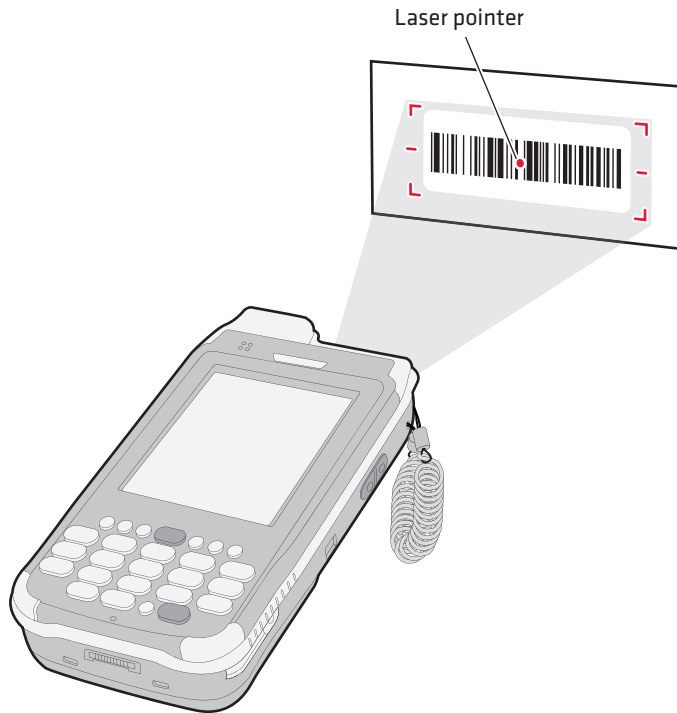

- 3** Center the pointer over the bar code label and move the CN4 so the bar code fills the aiming frame.
- 4** When a bar code label is successfully read, the CN4 makes a high beep and the Good Read LED lights briefly.
- 5** Release the **Scan** button.

By default, these bar code symbologies are enabled on the CN4:

- Code 39
- Code 128/GS1-128
- DataMatrix
- EAN-8
- EAN-13
- PDF417
- UPC-A
- UPC-E

If you are using bar code labels that are encoded in a different symbology, you need to enable the symbology on the computer. Use Intermec Settings to enable and disable symbologies. For help, see **“Configuring the CN4 Parameters” on page 48.**

## Improving Imager Performance

If you experience problems reading bar codes, try some of these tips to improve the imager performance.

- Keep your hand as steady as possible while scanning a label.
- Position the imager as close to the bar code as possible while still being able to capture the entire bar code.
- Enable only the bar code symbologies that you need to use every day.

You can also choose a predefined mode that optimizes imager settings for different needs or environments.

### To choose a predefined mode for the imager

- 1 Start Intermec Settings. For help, see **“Configuring the CN4 Parameters” on page 48.**
- 2 Tap **Data Collection > Internal Scanner > Imager Settings > General** and then choose an option from the **Predefined Modes** list:

Predefined Mode	Select If You Are Scanning:
1D	Only 1D labels.
1D and 2D Standard	(Default) All types of bar code labels.
1D and 2D Bright Environment	In high ambient light, such as outdoors in the sunshine.
1D and 2D Reflective Surface	Glossy labels.
Custom	In conditions that require customized settings. For complete information about these settings, commands, and parameters, see the <i>Intermec Settings Command Reference Manual.</i>

- 3 Save your settings.



## Capturing Images

The Data Collection Resource Kit includes .NET classes you use in your image capture applications. For more information, see [“Developing Applications for the CN4” on page 72.](#)

The CN4 includes Image Capture, a utility application that demonstrates this feature.

### Using the Image Capture Application

**1** Tap **Start** > **Programs** > **Image Capture**.

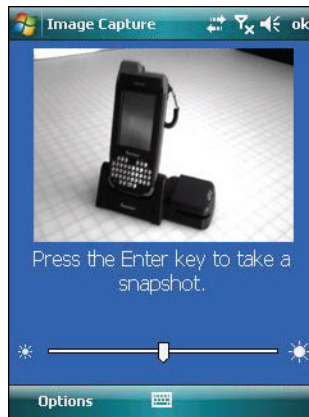

The Image Capture main screen shows streaming video from the imager.

- 2** (Optional) Adjust the Contrast slider for the best image:
- For brightly lit environments, move the slider to the right.
  - For dark areas, move the slider to the left.



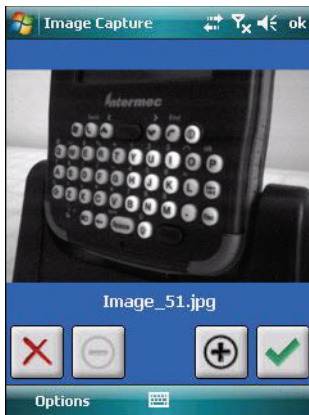

**Note:** For best results, move the slider a little at a time until you see a change in the onscreen image.

- 3 Point the CN4 at the subject for the image and press **Enter**. The image appears.



- 4 Tap-and-drag to scroll the image.



Tap  to zoom in, or tap  to zoom out.



To save the image, tap .

To discard the image, tap .

By default, images are saved to the My Documents\ImageCapture directory on the CN4, with the filename Image\_\$(*image\_number*). After you save or discard an image, the main screen appears and the CN4 is ready to capture another image.

- 5 To view saved images, tap **Options** and choose **Gallery**.

Tap  and  to view the images one at a time.

Tap  to zoom in, or tap  to zoom out.

To discard the image, tap . To discard all saved images, tap **Options** and choose **Delete All Files**.

To exit the Gallery, tap **Options** and choose **Exit Gallery**.

- 6 To close the application, tap **ok**.

## Configuring the Image Capture Application

The default Image Capture settings apply to most situations where the ambient lighting is adequate for office work. However, you may need to change those settings depending on the conditions in which images will be captured, such as outdoors in bright sunlight or inside a darkened warehouse.

### To configure Image Capture settings

- 1 Tap **Options** and choose **Settings**.
- 2 Change settings as needed. For help, see the next table.

#### *Image Capture Settings Descriptions*

Setting	Description
Edge Enhancement	Adjusts contrast to enhance the edges of objects. Default is Medium. Too high a setting for the environment adds noise to the image.
Lighting Correction	Corrects for inconsistent lighting; for example, if the edges of the image are much darker than the center, this feature lightens the edges to match the center. Default is Disabled.
Noise Reduction	Reduces noise resulting from edge enhancement. Range is 0 (default) to 9. Too high a value can cause banding.
Subsampling	Sets the resolution of the image by choosing a ratio. A ratio of 1:4 means that the processed image will contain 1 pixel for every 4 pixels in the original image. The lower the ratio, the larger and more detailed the image. Range is 1:2 to 1:8. Default is None.
Rotation	Rotates the processed image clockwise in 90° increments. Default is 0 (no rotation).
File Format	File type for saved images. Choose either BMP (default) or JPEG format.
Compression Quality	Sets JPEG compression quality. Range is 0 to 100%. Default is 60.

- 3 Tap **Options** and choose **Save Changes and Exit**, or choose **Discard Changes and Exit** to abandon your changes.

## Copying Images to Your Desktop PC

You can connect to the CN4 with ActiveSync and browse to the \My Documents\ImageCapture directory to download image files to your desktop PC. For help, see [“Connecting to a PC” on page 45](#).

You can also use other automated file transfer methods to copy files.

## Integrating Image Capture Into Your Application

You can integrate Image Capture into your own application by calling it from your application. You can also customize Image Capture settings by creating and editing the Image Capture configuration .xml file. For help, see [“Integrating Image Capture” on page 76](#).

## Capturing Signatures

A signature capture is a grayscale image of a signature on paper or other business form. To use signature capture in your applications, use the SignatureCapture components in the Data Collection Resource Kit.

Ink capture is the process of saving an onscreen image, such as a signature or simple line drawing, to a file. To use ink capture in your applications, use the InkCapture components in the Mobile Gadgets Resource Kit.

For more information, see [“Developing Applications for the CN4” on page 72](#).

## Capturing Documents (EA21 only)

Use the Intermec Enhanced Mobile Document Imaging (eMDI) application to capture documents and create electronic files of printed documents.



**Note:** The eMDI application places a watermark on the captured documents until you purchase the eMDI Client Software License (P/N 454-025-001). For more information, contact your local Intermec representative.

## To use the eMDI application

- 1 Tap **Start** > **Programs** > **Document Imaging**.

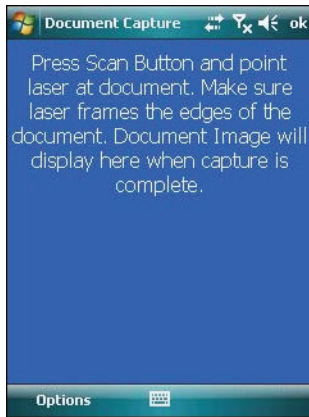

- 2 Point the CN4 at the document to be captured.
- 3 Press and hold the **Scan** button. A laser pointer, illumination beam, and aiming frame turn on.

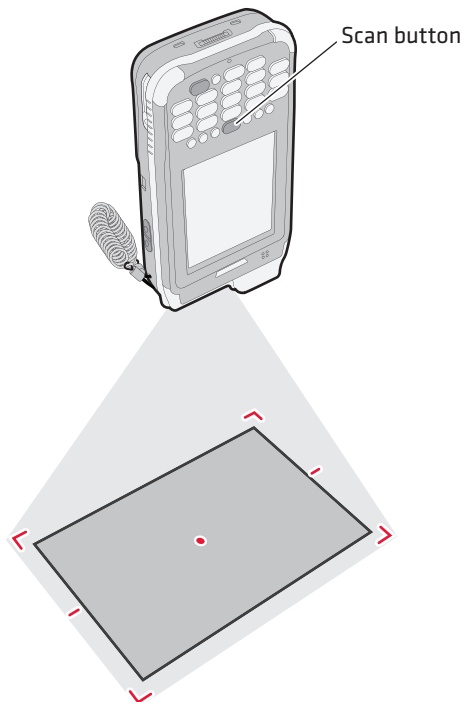

- 4 Keep the pointer centered on the document and move the CN4 so the aiming frame approaches the edges of the document.

When the frame stops flashing, the CN4 captures the document.

- 5 Release the **Scan** button. The captured image appears.



- 6 Tap-and-drag to scroll the image.

Tap to zoom in, or tap to zoom out.

To save the image to the Gallery, tap .

To discard the image and try again, tap .

- 7 To close the application, tap **ok**.

You can use eMDI as a standalone application, or you can call eMDI from your own application. For more information, see the *Enhanced Mobile Document Imaging User's Guide*.

You can also access the document capture APIs by using components in the Data Collection Resource Kit. For more information on Resource Kits, see “**Developing Applications for the CN4**” on page 72.

# Using the Color Camera



**Note:** The CN4 can be ordered with either a color camera or one of the the area imagers, but not both.

The optional, 2-megapixel color camera with flash is factory-installed in the upper back of the CN4, as shown in the following illustration.

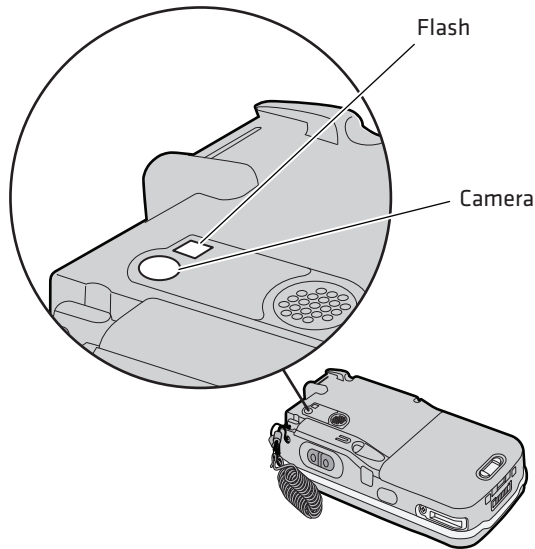

## ***Color Camera and Flash Location***

You can take photos in either high-resolution or compressed format, with resolutions up to 1600 x 1200 pixels. When you take a picture, the images are saved as .jpg files and stored in the /My Documents/My Pictures folder.

You can use the Pictures & Videos application on the CN4 to take, view, and edit pictures or record and launch video clips stored on the CN4 or a storage card. You can also send pictures and video clips to others or save an image as the background on the Today screen.

After the color camera is enabled, you can configure camera options by going to **Menu > Options** or **Menu > Tools > Options** from the Pictures & Video screen. While you are in the Pictures & Videos application, you can select **Start > Help** for more information on using the camera.

### To take a picture with the camera

- 1 Tap **Start > Programs > Pictures & Videos**.
- 2 Tap the **Camera** option in the grid or tap **Camera** in the taskbar.

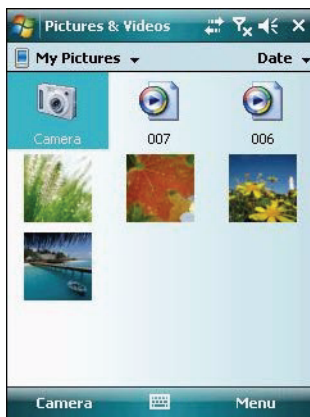

- 3 Using the screen display as a viewfinder, move the camera until you have the image you want to capture.
- 4 Press **Enter** to save the image. If you select to save your pictures to main memory, they are saved to permanent storage on the CN4.

### To save picture files

- 1 Tap **Menu > Options > the Camera** tab.
- 2 Select a file save location, type a filename prefix, and select a compression level.
- 3 Tap **ok**.



# Installing a miniSD or SIM Card



Warning

You can corrupt your miniSD card if you do not follow these installation and removal procedures exactly. Before installing a miniSD card, inspect the gasket in the compartment for any damage or wear, and contact your Intermec representative if you find any damage or wear.

The miniSD card and SIM card slots are located below a door inside the CN4 battery compartment.

When the door to the miniSD is opened and closed (for changing, installing, or removing the SIM or miniSD card), the CN4 performs a cold boot after you install the battery. For more information, see [“Cold Booting the CN4” on page 98](#).

## To insert a miniSD or SIM card

- 1 Press the **Power** button to suspend the CN4, and then remove the battery. For help with removing the battery, see [“Changing the Battery” on page 4](#).
- 2 Remove the two screws on the miniSD/SIM card slot door.

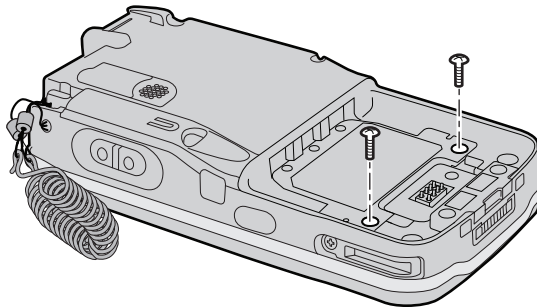

- 3 Gently lift the door to the card slot.
- 4 Insert the SIM card or miniSD card as shown in the next illustrations.

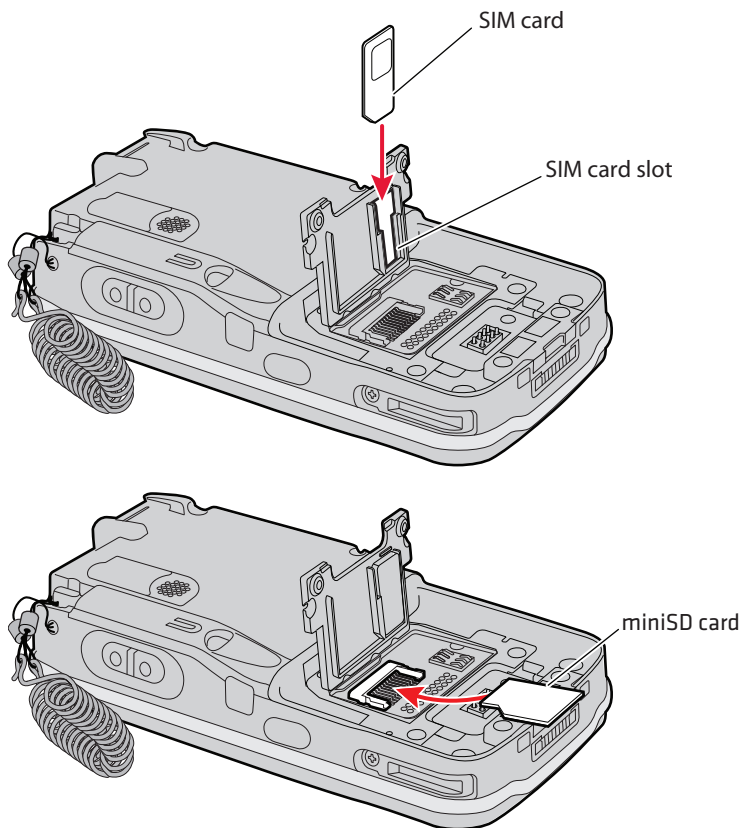

- 5** Close the miniSD/SIM card slot door and insert the two screws.



**To prevent damage to the door, do not overtighten the screws that secure the card slot door.**

- 6** Replace the battery pack and then press the **Power** button. The CN4 cold boots.

## Setting Up GPS on Your CN4

The integrated Global Positioning System (GPS) receiver in your CN4 delivers standards-based National Marine Electronics Association (NMEA) data strings to GPS applications. However, Intermec recommends that you use the GPS Intermediate Driver (GPSID) instead of directly accessing the GPS hardware. The GPSID is a Microsoft software component that interacts between applications and the GPS hardware.

Using the GPSID allows Intermec support for Extended Ephemeris, which enhances GPS performance by:

- reducing the amount of time it takes your GPS receiver to acquire a fix.
- eliminating the need to obtain precise satellite data information from the GPS satellites.

As a Microsoft software component, the GPSID also:

- allows multiple applications to simultaneously access the GPS data stream.
- provides access to GPS data without requiring applications to recognize and parse NMEA syntax.

## Using the GPSID Installed on the CN4

To use the GPSID installed on your CN4, you need to configure the GPSID settings.

### To configure your GPSID settings

- 1 Tap **Start** > **Settings** > the **System** tab.

- 2 Tap **External GPS**. The GPS Settings screen appears.

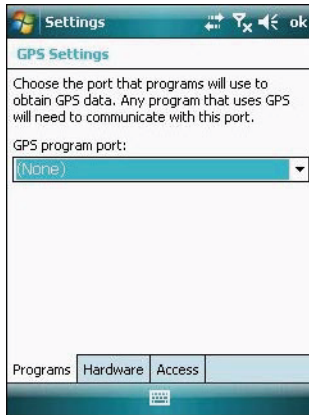

- 3 On the **Programs** tab, select the COM port that you want your programs to use to get GPS data from your CN4.



**Note:** COM1 and COM3 are reserved.

- 4 Tap the **Hardware** tab, and select these settings.

GPS hardware port: COM3

Baud rate: 57600

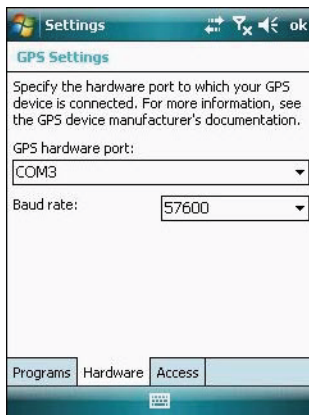

- 5 Tap the **Access** tab and select the **Manage GPS automatically** check box.

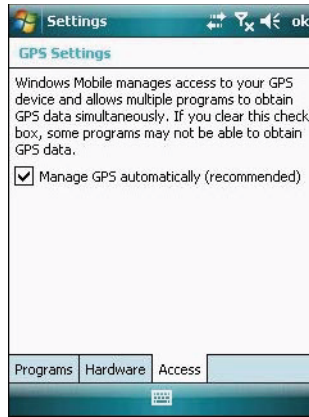

- 6 Tap **ok**.

**To enable extended ephemeris**

- 1 Tap **Start > Settings > the System** tab.
- 2 Tap **iGPS settings**. The iGPS Settings screen appears.
- 3 Tap the **Advanced** tab.

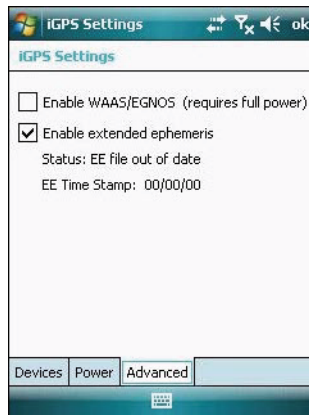

- 4 Select the **Enable extended ephemeris** check box.
- 5 Tap **ok**.

## **Learning About Additional GPS Options for the CN4**

Intermec provides enhanced feature support for the Extended Ephemeris data capability. For the latest Extended Ephemeris data files and other CN4 downloads, visit the CN4 downloads page on the Intermec website at [www.intermec.com](http://www.intermec.com). For more information about programming for Extended Ephemeris GPS, visit the Intermec Developer Library at [www.intermec.com/idl](http://www.intermec.com/idl).

# 2

## Connecting and Configuring the CN4

Use this chapter to understand how to configure the CN4 to communicate in your network. This chapter contains these topics:

- **Managing the CN4 With SmartSystems Foundation**
- **Connecting to a PC**
- **Configuring the Phone**
- **Configuring the CN4 Parameters**
- **Configuring the CN4 for Your Network**
- **Configuring Wireless Security**

# Managing the CN4 With SmartSystems Foundation

Intermec's SmartSystems™ Foundation is a software platform that lets you manage all of your SmartSystems-enabled devices, including the CN4, simultaneously from a central server. The SmartSystems console displays all SmartSystems-enabled computers and peripherals in your network.

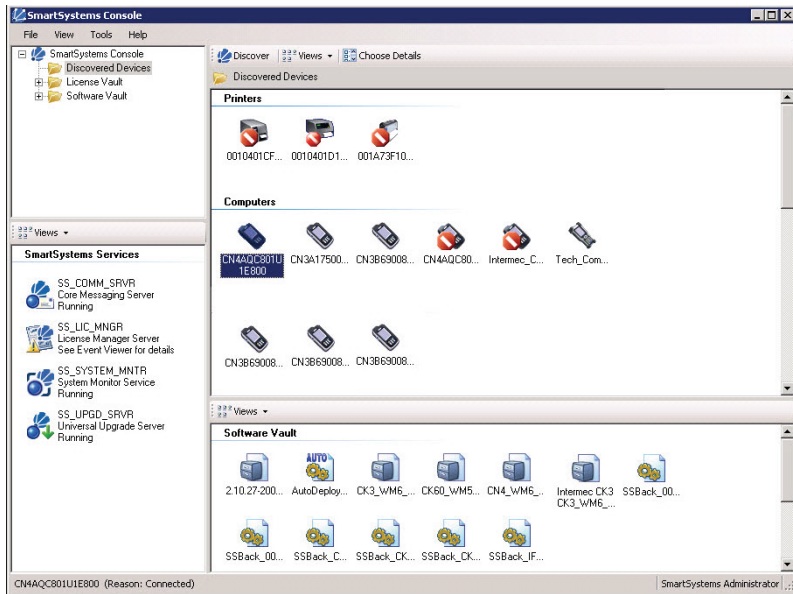

## Intermec SmartSystems Foundation Console

Through the console, you can:

- drag-and-drop configuration bundles, operating system updates, and firmware upgrades to multiple computers.
- save configuration settings from a single device and deploy those settings to many devices simultaneously.
- remotely change settings on SmartSystems-enabled computers and peripherals.

The SmartSystems console can report on asset locations and battery status, making it easier to manage your mobile devices.



With an AutoDeploy license, SmartSystems can automatically push software, configuration settings, and other files to connected CN4s. The license also enables Scan-to-Connect, which makes connecting additional CN4s to your wireless network as easy as reading bar codes.

SmartSystems Foundation can be downloaded at no charge from the Intermec website. For more information, visit [www.intermec.com\SmartSystems](http://www.intermec.com\SmartSystems). To purchase an AutoDeploy license, contact your local Intermec sales representative.

## Connecting to a PC

You can connect the CN4 to your desktop PC to transfer and synchronize files, remotely debug applications, and perform other device management activities. Visit [www.windowsmobile.com\getstarted](http://www.windowsmobile.com\getstarted) to learn more about synchronizing your CN4 with a desktop PC.

Use Microsoft ActiveSync to establish a connection between your CN4 and PC. ActiveSync can be downloaded for free from Microsoft. To establish an ActiveSync partnership between your CN4 and PC, you need to physically connect your CN4 to your PC using:

- an AD10 single dock and USB to mini-USB cable.
- an AA18 USB adapter and USB cable.

### To establish an ActiveSync partnership

- 1 Download ActiveSync from the Microsoft website and install ActiveSync on your PC. When installation is complete, the Get Connected dialog box appears.
- 2 Follow the onscreen instructions to establish a partnership. When the partnership is established, the Microsoft ActiveSync screen appears on your PC.

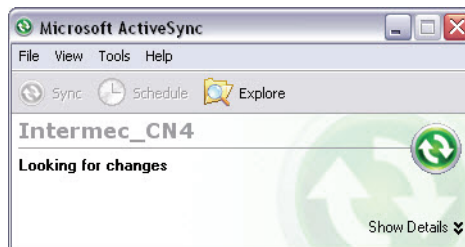

## Configuring the Phone

The CN4 supports two types of cellular phone technology:

- CDMA EV-DO Rev A
- UMTS and GSM/EDGE

With the radio module installed in the CN4, you can send and receive telephone calls as well as transmit data through wide-area (WAN) cellular networks.

The CN4 provides a phone speaker, microphone, and speakerphone. It also supports Bluetooth headsets or hands-free kits.

By default the phone is enabled. After you activate the phone, you can customize the features of the phone and network settings. For help, refer to the Windows Mobile help on your CN4.

## Activating the CDMA Phone

The CDMA WAN radio module is installed at the factory. To activate your CDMA CN4, contact the carrier you have chosen and set up accounts for each device. The following table lists the carriers that Intermec currently supports. If your carrier is not listed in the table, please contact Intermec product support to see if it is now supported.

### **Currently Supported Carriers**

Country	Carrier
United States	Sprint, Verizon
Canada	Bell Mobility

The carrier will require the Electronic Serial Number (ESN) to start the activation process. You can find the ESN:

- on a label located in the upper right corner of the battery compartment.
- on the outside of the CN4 shipping box.

The activation process is slightly different for each CDMA carrier. Your carrier sales contact and an Intermec representative can guide you through the process.

After you supply the ESN to your carrier, they will respond with values that you must enter using the Windows Mobile Activation Wizard (if required). Some of the supported carriers do not require you to enter any values. The following table shows the carriers, the correct activation method to use, and the values that you need to activate your phone.

**Values Required for CDMA Phone**

<b>Carrier</b>	<b>Activation Method</b>	<b>Activation Values You Need</b>
Bell Mobility	Activation Wizard	Service Programming Code (SPC), also called the activation code Mobile Directory Number (MDN) Mobile Station Identification Number (MSIN) System ID (SID) Network ID (NID) Mobile Country Code (MCC) Mobile Network Code (MNC) Username Password
Sprint	Activation Wizard	Master Subsidy Lock (MSL), also called the activation code MDN Mobile Station Identifier (MSID)
Telecom New Zealand	Activation Wizard	SPC SID NID
Verizon	Dial *22899, or Activation Wizard	None - all parameters are automatically transferred wirelessly.

After activation, the settings are permanently stored in the CDMA module. Changing the OS or SSPB loads will not affect any of the settings or activation parameters stored in the WAN modem.

**To start the Activation Wizard**

- 1** Tap **Start > Phone**.
- 2** In the Phone application, tap **Menu > Activation Wizard**.

## Activating the GSM/EDGE Phone

You use a SIM card to activate the GSM/EDGE phone on the CN4. You can purchase the SIM card from your network provider.

### To activate the GSM/EDGE phone

- Install the SIM card in the CN4. For help, see [“Installing a miniSD or SIM Card” on page 37.](#)

You may need to configure network settings for your provider. For information, tap **Start** > **Help** and see the procedures in the Windows Mobile online Help. Or, contact your network provider.

## Making a Phone Call

After you activate your phone, you are ready to start making phone calls.

### To make a phone call

- 1 Tap **Start** > **Phone**.
- 2 Tap the keys to enter the telephone number you want to call.
- 3 Tap the **Talk** button.

## Turning the Phone On and Off

Use the iConnect utility to turn the phone on or off. For help, see [“Managing Network Connections With iConnect” on page 58.](#)

## Configuring the CN4 Parameters

You can configure many parameters on the CN4 such as the bar code symbologies it decodes or the network settings. The values you set for these parameters determine how the CN4 operates.

Operating parameters can be viewed and changed on the CN4 by using the Intermec Settings application on the computer. There are two ways to access Intermec Settings:

- Remotely via Intermec SmartSystems Foundation. When you use SmartSystems, you can remotely configure all your CN4 computers as well as other SmartSystems-enabled Intermec

computers and peripherals. For more information, see the next section.

- Directly on the CN4. Using Intermec Settings on the CN4 changes only the settings on that computer. For more information, see **“Using Intermec Settings Directly On the CN4” on page 50.**
- You can use a third-party device management product that includes Intermec Settings Configuration Support, such as the Microsoft System Center Mobile Device Manager. Visit <http://www.microsoft.com/systemcenter/mobile> for more information.

You can also configure the CN4 with configuration bundles that you create using SmartSystems Foundation. For more information, see the SmartSystems Foundation online Help.

## **Using Intermec Settings Remotely With SmartSystems Foundation**

Your CN4 is SmartSystems-enabled, which lets you open Intermec Settings from the SmartSystems console to remotely configure all of your CN4 computers.

For more information on SmartSystems, see **“Managing the CN4 With SmartSystems Foundation” on page 44.**

### **To open Intermec Settings from the SmartSystems console**

- 1** In the SmartSystems console, right-click a CN4.

## 2 Select Intermec Settings.

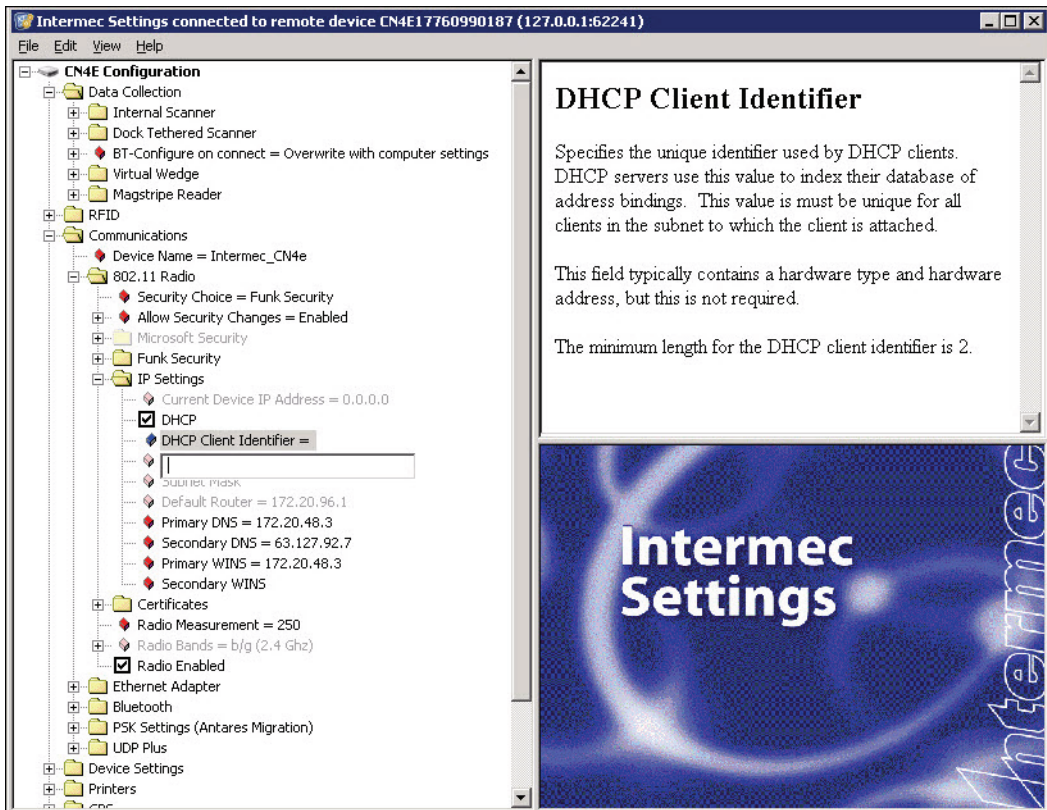

3 Change settings as needed. As you choose parameters, information on each parameter appears in the upper right-hand pane of the Intermec Settings browser.

4 When you are done making changes, choose **File > Save Settings**. For help with using Intermec Settings, in the browser click **Help > Contents**.

For information on all parameters in Intermec Settings, see the *Intermec Settings Command Reference Manual*.



## Using Intermec Settings Directly On the CN4

You can use Intermec Settings on the CN4 to configure the computer and view system information.

## To use Intermecc Settings

- 1 On the CN4, tap **Start** > **Settings** > the **System** tab > **Intermec Settings**.



- 2 Tap a menu bar. A new menu or a list of configurable items appears.
- 3 In a list of configurable items, choose or change options by entering data in the entry fields or checking the appropriate check box.
  - To restore the default settings to all items in the current menu, tap **Menu** > **Restore Menu Defaults**. Tap **Yes** to clear the confirming message and restore menu defaults.
  - To restore all default settings, tap **Menu** > **Restore All Defaults**. Tap **Yes** to clear the confirming message and restore all defaults, which may take a few minutes.
- 4 Tap **Back** or  to save your changes and go back to the previous screen.  
Tap  to return to the main menu.
- 5 To close Intermecc Settings, in the main menu tap **ok** or choose **Menu** > **Exit**.

For more information on all parameters in Intermecc Settings, see the *Intermec Settings Command Reference Manual*.

## Hiding Menu Items in Intermec Settings

In Intermec Settings, you can hide items in the CN4 menus, or in the directory tree in the SmartSystems console. Hidden items are not saved when you back up your settings in the SmartSystems console.

In Intermec Settings in the SmartSystems console:

- To hide menu items, right-click a menu item and choose **Hide Menu Item** from the popup list. Click **Yes** to clear the confirming message.
- To restore menu items, click the CN4 name at the top of the directory tree to select it, and then choose **View > Unhide Items**. All hidden menu items are restored.

In Intermec Settings on the CN4:

- To hide menu items, tap and hold the item, and then choose **Hide Menu Item** from the popup list. Tap **Yes** to clear the confirming message.
- To restore hidden items in a single menu, tap and hold the menu bar where the item was hidden, and then choose **Restore Item Default** from the popup list.
- To restore all hidden items in all menus, tap **Menu > Unhide All Items**.



**Note:** When you restore default settings in Intermec Settings, only the settings for visible items are restored to defaults. The settings for hidden menu items are not affected. For more information, see the SmartSystems Foundation online Help.

## Configuring the CN4 for Your Network

You can easily add the CN4 to your wireless or wired data collection network. You can connect your CN4 using:

- 802.11b/g radio communications.
- Ethernet communications.
- Bluetooth communications.
- USB and serial communications.



## Configuring 802.11b/g Radio Communications



**Make sure all components with antennas are at least 30 cm (1 ft) apart when power is applied. Failure to comply could result in equipment damage.**

Your CN4 has an 802.11b/g radio to transfer data using wireless communications and supports the TCP/IP network protocols. This section of the manual assumes that your wireless network is set up, including your access points.

### To use wireless communications in a TCP/IP network

- 1 Configure these parameters on each CN4 in the network:
  - Network name (SSID)
  - IP settings (if not using DHCP)
- 2 Make sure your CN4 is talking to the network and that the network can see your CN4. For more information, see [“Managing Network Connections With iConnect” on page 58.](#)
- 3 Configure security. For help, see [“Configuring Wireless Security” on page 59.](#)

## Configuring Ethernet Communications

You connect your CN4 to your Ethernet network with an Ethernet cable and one of these accessories:

- AD10 single dock with an Ethernet/modem (AA12/AA13) adapter
- AD11 Ethernet multidock
- AA16 Ethernet snap-on adapter

### To use your CN4 in an Ethernet network

- 1 Connect the CN4 to an Ethernet network with an AD10, AD11, or AA18. Ethernet communication is enabled by default on the CN4.
- 2 Configure these network parameters:
  - If you have a DHCP server, enable DHCP.
  - If you do not have a DHCP server, set these parameters:
    - a IP address

- b** Subnet mask
  - c** Default router
- 3** If necessary, set these parameters:
    - Primary and secondary DNS servers
    - Primary and secondary WINS servers
  - 4** Make sure that your CN4 is communicating with the network and that the network can see your CN4. For more information, see **“Managing Network Connections With iConnect” on page 58.**

## **Configuring Bluetooth Communications**

Your CN4 is Bluetooth™ enabled, which lets you connect to other Bluetooth devices, such as scanners, printers, or audio devices.

You need to turn on the Bluetooth radio before you can discover and connect to other Bluetooth devices. By default, the radio is turned off. Use Intermec Settings to enable the radio and configure other Bluetooth settings as described next.

### **To turn on the Bluetooth radio and configure Bluetooth settings**

- 1** Start Intermec Settings.
- 2** Choose **Communications > Bluetooth**.
- 3** Choose **On** from the Power menu. A message appears asking if you want to save the new settings.
- 4** Choose **Yes**. Intermec Settings refreshes the settings and returns you to the main menu.
- 5** (Optional) To make the CN4 visible to other Bluetooth devices, choose **Communications > Bluetooth** and choose **Enable** from the Discoverable menu.

To make the CN4 connectable to other Bluetooth devices that discover it, choose **Communications > Bluetooth** and choose **Enable** from the Connectable menu.
- 6** Click **OK**.

The Bluetooth radio maintains its state through a warm or cold boot and maintains virtual COM ports. But, if you clean boot your CN4 you need to recreate pairings to devices.

## Connecting to a Bluetooth Scanner

You can connect to an Intermec Bluetooth scanner, such as the SF51 or SR61, by using the Wireless Scanning enabler.

### To use the Wireless Scanning enabler

- 1 Tap **Start** > **Settings** > the **System** tab > **Wireless Scanning**.



- 2 Tap **Add Device**.

- 3 To add a scanner by scanning a bar code on the CN4:

- a Tap **Quick Connect** and then tap **Next**.
- b Scan the bar code with the scanner and then tap **Finish**.

To search for scanners:

- a Tap **Search** and then tap **Next**. The CN4 looks for scanners, and the Bluetooth device names of found scanners appears in the list.
- b Tap the scanner device name in the list and then tap **Next**. The scanner is paired with the CN4.

To manually add a scanner:

- a Tap **Manual** and then tap **Next**.
- b Enter the Bluetooth address of the scanner in the entry field.
- c Tap **Next**. The scanner is paired with the CN4.

## Connecting to a Bluetooth Printer

- 1 Choose **Start** > **Settings** > the **System** tab > **Wireless Printing**.

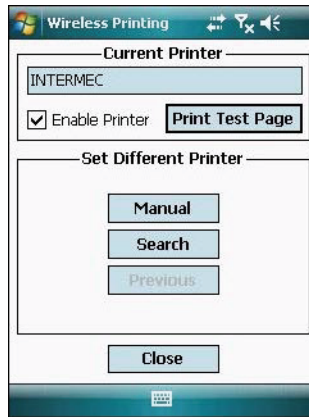

- 2 To search for printers:
  - a Tap **Search**. The CN4 looks for printers, and the Bluetooth device names and addresses of found printers appear in the list.
  - b Tap a printer device name in the list to select it, and then tap **Set**.

To manually add a printer:

- Tap **Manual**, enter the Bluetooth device address for the printer in the entry field, and then tap **Set**.

- 3 (Optional) Tap **Print Test Page**. The printer prints out a test page.

After you configure Bluetooth wireless printing, you can use an application that opens the wireless printing COM port on your CN4. For help with developing applications, see the Bluetooth Resource Kit, part of the Intermec Developer Library (IDL), available from the Intermec website at [www.intermec.com/idl](http://www.intermec.com/idl).



**Note:** You can also print wirelessly using Microsoft APIs with Bluetooth extensions for Winsock and Bluetooth virtual COM ports. For help, see the Bluetooth Resource Kit documentation.

## Connecting to a Bluetooth Audio Device

Use the Bluetooth Audio enabler to discover, activate, and connect to Bluetooth audio devices such as a headset. This enables system sounds to be monitored through the headset.

### To connect to a Bluetooth audio device

- 1 Select **Start > Settings > the System tab > Bluetooth Audio**. The Bluetooth Audio screen appears.

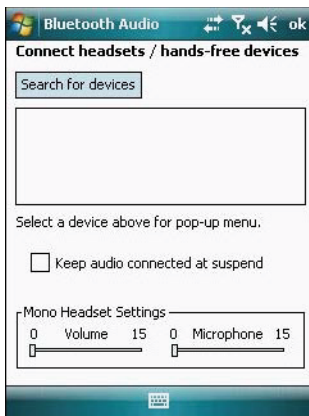

- 2 Follow the onscreen instructions to connect to a Bluetooth audio device.

## Using Serial and USB Communications

You can use these CN4 accessories to transmit data to and receive data from another device through serial or USB communications:

- AD10 single dock
- AV6 vehicle dock (AV9 for CN4e)
- AA18 USB adapter
- AA17 RS-232/DEX adapter

For more information about these accessories and how to order them, see **“Accessories” on page 109**.

## Managing Network Connections With iConnect

After you configure 802.11 or Ethernet network settings, you can use the iConnect utility to:

- check the network connection status with a ping test.
- change basic network parameters.
- change Funk security profile settings.
- turn the 802.11 radio, Ethernet, phone, or Bluetooth radio on and off.

### To turn a network connection on or off

- 1 Tap the iConnect icon () in the lower right corner of the Today screen.
- 2 Choose **Enable** and then choose a network connection from the list. A check mark next to the connection type indicates that the connection is enabled.

### To configure or change wireless security profile settings

- 1 Tap the iConnect icon () in the lower right corner of the Today screen.
- 2 Choose **Tools > Wireless Settings**. The Profile Wizard appears.
- 3 Choose a profile from the Profile list and change settings as needed. For more information, see [“Selecting a Funk Security Profile” on page 61](#).

### To configure or change wireless or Ethernet network settings

- 1 Tap the iConnect icon () in the lower right corner of the Today screen.
- 2 Choose **Tools > Wireless IP Settings** or **Ethernet IP Settings**. A dialog box appears that shows the current settings for the wireless or Ethernet network adapter.
- 3 Change settings as needed and click **ok**.

### To check the connection status with a ping test

- 1 Tap the iConnect icon () in the lower right corner of the Today screen.
- 2 Choose **Tools > Ping Test**.

- 3 Choose **Ethernet** or **Wireless** from the connection type list.
- 4 Choose **Ping my gateway or DHCP server** if you are using DHCP. Or, choose **Ping the host address below** and enter the host address in the entry field.
- 5 Tap **Ping**. The ping test runs and checks your connection. If the connection is OK, “Connection Validated” appears.

**To check overall connection status**

- 1 Tap the iConnect icon () in the lower right corner of the Today screen.
- 2 Choose **Status > Ethernet** or **Wireless**. A message box appears. iConnect checks these items in order:
  - Network connection (Ethernet or wireless) enabled
  - MAC address of the CN4 network adapter
  - MAC address of the associated host
  - IP address of the CN4
  - Ping Status
- 3 Tap **Try Again** to test the connection again.

If you are having trouble with your wireless connection, you can use iConnect to verify available access points and networks, check signal strength, and view other diagnostics. For help, see “[Checking 802.11 Network Status](#)” on page 94.



**Note:** If you choose **Exit iConnect** from the menu, the desktop icon disappears. To restore the iConnect desktop icon, warm boot the CN4.

## Configuring Wireless Security

The CN4 provides four types of security for your wireless network:

- Wi-Fi Protected Access 2 (WPA2™)
- Wi-Fi Protected Access (WPA)
- 802.1x
- WEP

This section explains how to configure wireless security on your CN4. If you choose not to use security, see **“Disabling Security” on page 70**. Intermec recommends that you always implement security.

You must use either Funk or Microsoft security to implement your security solution. For details, see the next section, **“Choosing Between Microsoft and Funk Security.”**

If you are using WPA-802.1x, WPA2-802.1x, or 802.1x security, this section also assumes that your authentication server and authenticators are properly configured.



**Note:** Your security choice does not depend on your authentication server. For example, you can choose Funk security if you use Microsoft Active Directory® to issue certificates.

### Choosing Between Microsoft and Funk Security

The CN4 supports both Funk and Microsoft security, which dynamically select wireless networks based on your preferences. The option you choose depends on your network security needs.

- If you are using the CN4 in a static environment that requires a high level of security, you should use Funk security, which offers these additional features:
  - CCX v4.0 compliance
  - Support for LEAP and TTLS
  - Configuration of up to four profiles

To use Funk security, you need to select a profile. For help, see the next section, **“Selecting a Funk Security Profile.”**

- If you are primarily using the CN4 to connect to WiFi hotspots, you may want to use Microsoft security.

To use Microsoft security, you need to select it as your security choice. For help, see **“Selecting Microsoft as Your Security Choice” on page 65**.



## Selecting a Funk Security Profile

You can define up to four profiles for Funk security. Different profiles let your CN4 communicate in different networks without having to change all of your security settings. For example, you may want to set up one profile for the manufacturing floor and one for the warehouse. By default, the active profile is Profile 1.



**Note:** You can also use the Profile Wizard to configure most wireless security settings. To start the Profile Wizard, tap the iConnect icon () in the lower right corner of the Today screen and select **Tools > Wireless Settings**.

### To select a Funk security profile

- 1 Start Intermec Settings.
- 2 Choose **Communications > 802.11 Radio > Funk Security**.
- 3 Choose a profile. A list of configurable settings appears.
- 4 (Optional) In the **Profile Label** text box, enter a meaningful name for your profile.
- 5 Configure your security settings. For help, see the next sections.
- 6 Repeat Steps 3 through 5 for each profile you want to define.
- 7 Set an active profile by choosing it in the **Active Profile** list.
- 8 Save your settings.

### Configuring WPA Security With Funk Security

Use these procedures to set WPA-802.1x, WPA2-802.1x, WPA-PSK, or WPA2-PSK security on your CN4 with Funk security.

#### To configure WPA-802.1x or WPA2-802.1x with Funk security

- 1 Make sure the communications and radio parameters on your CN4 are configured.
- 2 Make sure Funk is selected as your security choice.
- 3 Start Intermec Settings.
- 4 Choose **Communications > 802.11 Radio > Funk Security**.
- 5 Select the profile you want to configure.
- 6 For **Association**, choose **WPA** or **WPA2**. Encryption automatically defaults to **TKIP** or **AES**, respectively.

**7** For **8021x**, choose **TTLS**, **PEAP**, **EAP-FAST**, or **TLS**.

**8** If you choose **TTLS** or **PEAP**:

**a** For **Prompt for Credentials**, choose **Enter credentials now**.

**Note:** You can use **Prompt for Credentials** to troubleshoot your network connection.



**b** Enter a **User Name** and **User Password**.

**c** For **Validate Server Certificate**, choose **Yes**.

**Note:** The correct date must be set on your CN4 when you enable **Validate Server Certificate**.



If you choose **TLS**:

**a** Load a user and root certificate on your CN4. For help, see [“Loading a Certificate” on page 68](#).

**b** Enter a **User Name** and **Subject Name**.

**c** For **Validate Server Certificate**, choose **Yes**.

**d** (Optional) To increase your level of security, enter a **Server 1 Common name** and a **Server 2 Common name**.

**9** Save your settings.

**To configure WPA or WPA2 with Funk security**

**1** Make sure the communications and radio parameters on your CN4 are configured.

**2** Make sure Funk is selected as your security choice.

**3** Start Intermec Settings.

**4** Choose **Communications** > **802.11 Radio** > **Funk Security**.

**5** Select the profile you want to configure.

**6** For **Association**, choose **WPA** or **WPA2**.

**7** For **8021x**, choose **None**.

- 8 For **Pre-Shared Key**, enter the pre-shared key or passphrase.

The pre-shared key must be a value of 32 hex pairs preceded by 0x for a total of 66 characters. The value must match the key value on the access point. The passphrase must be from 8 to 63 characters. After you enter a passphrase, the CN4 internally converts it to a pre-shared key.

This value must match the passphrase on the authenticator.

- 9 Save your settings.

### Configuring 802.1x Security With Funk Security

- 1 Make sure the communications and radio parameters on your CN4 are configured.
- 2 Make sure Funk is selected as your security choice.
- 3 Start Intermec Settings.
- 4 Choose **Communications** > **802.11 Radio** > **Funk Security**.
- 5 Select the profile you want to configure.
- 6 For **Association**, choose **Open**.
- 7 For Encryption, choose **WEP**.
- 8 For **8021x**, choose **TTLS**, **PEAP**, or **TLS**.
- 9 If you chose **TTLS** or **PEAP**:
  - a Enter a **User Name**.
  - b For **Prompt for Credentials**, choose **Enter credentials now**.

**Note:** You can use **Prompt for Credentials** to troubleshoot your network connection.



- c Enter a **User Password**.
- d For **Validate Server Certificate**, choose **Yes**.

If you choose **TLS**:

- a Load a user and root certificate on your CN4. For help, see **“Loading a Certificate” on page 68**.
- b For **Validate Server Certificate**, choose **Yes**.
- c Enter a **User Name** and **Subject Name**.

- d (Optional) To increase your level of security, enter a **Server 1 Common name** and a **Server 2 Common name**.

**10** Save your settings.

### **Configuring LEAP Security**

- 1** Make sure the communications and radio parameters on your CN4 are configured.
- 2** Make sure Funk is selected as your security choice.
- 3** Start Intermec Settings.
- 4** Choose **Communications > 802.11 Radio > Funk Security**.
- 5** Select the profile you want to configure.
- 6** For **8021x**, choose **LEAP**.
- 7** For **Association**, choose **Open**, **WPA**, **WPA2**, or **Network EAP**. Encryption automatically defaults to **TKIP** if you choose WPA, **AES** if you choose WPA2, and **WEP** if you choose Open or Network EAP.
- 8** For **Prompt for Credentials**, choose **Enter credentials now**.
- 9** Enter a **User Name** and **User Password**.
- 10** Save your settings.

### **Configuring Static WEP Security With Funk Security**

- 1** Make sure the communications and radio parameters on your CN4 are configured.
- 2** Make sure Funk is selected as your security choice.
- 3** Start Intermec Settings.
- 4** Choose **Communications > 802.11 Radio > Funk Security**.
- 5** Select the profile you want to configure.
- 6** For **Association**, choose **Open**.
- 7** For **Encryption**, choose **WEP**.
- 8** For **8021x**, choose **None**.
- 9** Define a value for the keys you want to use. You can define up to four keys (**Key 1** through **Key 4**).

Enter an ASCII key or a hex key that is either 5 bytes or 13 bytes long depending on the capability of the radio. Set a 5- byte value for 64-bit WEP or a 13-byte value for 128-bit WEP. Hex keys must be preceded by 0x and contain 5 or 13 hex pairs.

- 10** For **Transmit key**, choose the key you want to use for transmitting data.
- 11** Save your settings.

### Selecting Microsoft as Your Security Choice

The default security setting is Funk. If you want to use Microsoft security, you need to select it as your security choice. After you select Microsoft as your security choice, you will be prompted to save your settings and reset your CN4 for your change to take effect.

With Microsoft as your security choice, you can configure:

- WPA
- 802.1x
- Static WEP

#### To select Microsoft security

- 1** Start Intermec Settings. For help, see [“Configuring the CN4 Parameters” on page 48.](#)
- 2** Choose **Communications > 802.11 Radio > Security Choice.**
- 3** From the **Security Choice** list, select **Microsoft Security.** An alert box appears telling you that you must save your settings and warm boot the CN4 for the new security choice to take effect.
- 4** Choose **Yes.** The CN4 resets and starts with Microsoft Security as the Security Choice.

#### Configuring WPA Security With Microsoft Security

Use these procedures to set WPA-802.1x and WPA-PSK security on your CN4 with Microsoft security.

#### To enable WPA-802.1x with Microsoft security

- 1** Make sure the communications and radio parameters on your CN4 are configured.
- 2** Start Intermec Settings.

- 3** Choose **Communications > 802.11 Radio > Microsoft Security**.
- 4** For **Infrastructure Mode**, choose **Infrastructure**.
- 5** For **Network Authentication**, choose **WPA. Data Encryption** automatically defaults to **TKIP**.
- 6** For **802.1x Authentication**, choose either **MD5, TLS, or PEAP**.
- 7** If you choose **TLS**:
  - a** Choose **Properties > Run App**. The Auth. Settings dialog box appears.
  - b** Choose **Select**.
  - c** Select your certificate from the list and press **Enter**. The User Logon dialog box appears.
  - d** Enter a **User Name** and **Domain** and press **Enter**.

If you choose PEAP:

- a** Choose **Properties > Run App**. The Auth. Settings box appears.
  - b** Choose **Validate Server** and press **Enter**. When the radio starts to authenticate, the Network Password dialog box appears.
  - c** Enter a **User Name** and **Password** and select **Save Password**.
  - d** (Optional) In the **Domain** field, enter the Active Directory domain associated with the user account.
- 8** Save your settings.

**To enable WPA-PSK with Microsoft security**

- 1** Make sure the communications and radio parameters on your CN4 are configured.
- 2** Start Intermec Settings.
- 3** Choose **Communications > 802.11 Radio > Microsoft Security**.
- 4** For **Infrastructure Mode**, choose **Infrastructure**.
- 5** For **Network Authentication**, choose **WPA-PSK. Data Encryption** automatically defaults to **TKIP**.
- 6** For **Pre-Shared Key**, enter the pre-shared key or the passphrase.

The pre-shared key must be a value of 32 hex pairs preceded by 0x for a total of 66 characters. The value must match the key value on the authenticator. The passphrase must be from 8 to 63 characters. After you enter a passphrase, the CN4 internally converts it to a pre-shared key.

This value must match the passphrase on the authenticator.

- 7 Save your settings.

### Configuring 802.1x Security with Microsoft Security

- 1 Make sure the communications and radio parameters on your CN4 are configured.
- 2 Start Intermec Settings.
- 3 Choose **Communications** > **802.11 Radio** > **Microsoft Security**.
- 4 For **Infrastructure Mode**, choose **Infrastructure**.
- 5 For **Network Authentication**, choose **Open**.
- 6 For **Data Encryption**, choose **WEP**.
- 7 For **802.1X Authentication**, choose **TLS** or **PEAP**.
- 8 If you choose TLS:
  - a Choose **Properties** > **Run App**. The Auth. Settings box appears.
  - b Choose **Select**.
  - c Select your certificate from the list and press **Enter**. The User Logon dialog box appears.
  - d Enter a **User Name** and a **Domain**.

If you choose PEAP:

- a Choose **Properties** > **Run App**. The Auth. Settings box appears.
- b Select **Validate Server** and press **Enter**. When the radio starts to authenticate, the Network Password dialog box appears.
- c Enter a **User Name** and **Password** and select **Save Password**.
- d (Optional) In the **Domain** field, enter the domain.
- e Press **Enter**.

- 9 For **Network Key Setting**, choose **Automatic**.
- 10 Save your settings.

### Configuring Static WEP Security With Microsoft Security

- 1 Make sure the communications and radio parameters on your CN4 are configured.
- 2 Start Intermec Settings.
- 3 Choose **Communications** > **802.11 Radio** > **Microsoft Security**.
- 4 For **Network Authentication**, choose **Open**.
- 5 For **Data Encryption**, choose **WEP**.
- 6 For **Network Key Setting**, choose **Enter Key and Index**.
- 7 For **Network Key Value**, enter an ASCII key or a hex key that is either 5 bytes or 13 bytes long depending on the capability of the radio.  
  
Set a 5-byte value for 64-bit WEP or a 13-byte value for 128-bit WEP. Hex keys must be preceded by 0x and contain 5 or 13 hex pairs.
- 8 For **Network Key Index**, select the key you want to use for data transmission.
- 9 Save your settings.

## Loading a Certificate

To use transport layer security (TLS) with WPA or 802.1x security, you need a unique client certificate on the CN4 and a trusted root certificate authority (CA) certificate. Certificates are pieces of cryptographic data that guarantee a public key is associated with a private key. They contain a public key and the entity name that owns the key. Each certificate is issued by a certificate authority.

### To import a root certificate

- 1 Tap the iConnect icon () in the lower right corner of the Today screen. The iConnect pop-up menu appears.
- 2 Select **Tools** > **Wireless Settings**. The Profile Wizard appears.



**3** Tap **Edit Selected Profile** > the **Security** tab > **Get Certificates**.

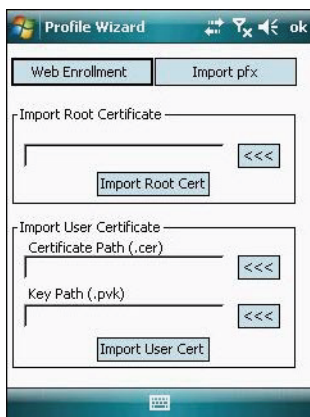

**Note:** PFX encoded certificates are also supported. Tap the **Import pfx** button to import a PFX encoded certificate.

- 4** To import a root certificate:
  - a** Tap the <<< button next to the **Import Root Certificate** field to select the root certificate (DER-encoded .cer file) to import.
  - b** Click **Import Root Cert** to install the selected certificate.
- 5** To import a user certificate:
  - a** Tap the <<< button next to the **Certificate Path** field to select the user certificate (DER-encoded .cer file without the private key) to import.
  - b** Tap the <<< button next to the **Key Path** field to select the private key (.pvk file) which corresponds to the user certificate you selected.
- 6** To import a certificate from an IAS server:
  - a** Tap **Web Enrollment**.
  - b** Enter the **User**, **Password**, and **Server** (IP address) to log into the server.
  - c** Tap **OK**. A dialog box appears asking if you want to load the root certificate.

- d** Tap **OK**. The Enrollment Tool message box appears telling you that the certificate has been added.
- e** Tap **OK** to close the message box.

## **Disabling Security**

If you choose not to use security with your wireless network, you can disable it on the CN4. Intermec recommends that you always set security in your network.

### **To disable security**

- 1** Start Intermec Settings. For help, see “**Configuring the CN4 Parameters**” on page 48.
- 2** Choose **Communications** > **802.11 Radio** > **Security Choice** and select **Microsoft Security**. An alert box appears telling you that you must save your settings and warm boot the CN4 for the new security choice to take effect.
- 3** Choose **Yes**. The CN4 resets and starts with Microsoft Security as the Security Choice.
- 4** Start Intermec Settings.
- 5** Choose **Communications** > **802.11 Radio** > **Microsoft Security**.
- 6** For **Network Authentication**, choose **Open**.
- 7** For **Data Encryption**, choose **Disabled**.
- 8** Tap **OK**. Your settings are saved.

# 3

## Developing and Installing Applications

Use this chapter to understand the guidelines for developing applications and installing them on the CN4. This chapter contains these sections:

- **Developing Applications for the CN4**
- **Installing Applications on the CN4**
- **Launching an Application Automatically**
- **Integrating Image Capture**
- **Freeing Up Virtual Memory for Applications**
- **Upgrading the System Software**

## Developing Applications for the CN4

Use the Intermec Resource Kits to develop applications to run on the CN4. The Resource Kits are a library of C++, .NET, Java, and web components grouped by functionality that you can use to create applications for the computer. The Resource Kits are part of the Intermec Developer Library (IDL), and can be downloaded from the Intermec website at [www.intermec.com/idl](http://www.intermec.com/idl).

For more information, see the *Intermec Developer Library Resource Kit Developer's Guide*.

### Packaging Your Application

For very simple applications, the executable file may be the only file you need to deploy. More typically, you will have a set of files to install.

For Windows Mobile applications, Intermec recommends creating a .cab file to install your application. The CN4 uses standard Windows Mobile .cab files and will install third-party .cab files.

### Choosing a Target Location for the Application

You can have your .cab file place your application in any of these memory locations on the CN4:

- The ObjectStore, which is RAM that looks like a disk.
- The optional miniSD card. Depending on available disk space, you may want to consider installing your application files on the miniSD card. Using a card creates the Storage Card folder on the CN4.
- The non-volatile Flash File Store. Applications and data in the Flash File Store will persist through a clean boot.

**Note:** The Flash File Store may be erased if you reflash the image.



If you need to cold boot the CN4, files copied to any of these locations are safe as long as the AutoRun system is installed in the appropriate location. When AutoRun is installed on the CN4, all .cab files in the CabFiles folder are automatically extracted after a cold boot. For more information about AutoRun, see the *Intermec Developer Library Resource Kit Developer's Guide*.

When you clean boot the CN4, all applications and data files in the ObjectStore are erased. The CN4 loads only the default files and programs required by the CN4 operating system. If you want to keep your applications (and configurations) during a clean boot, make sure that the \_sstransferagent.xml is updated and is in this directory:

- \Flash File Store\UserAutoInstall

During the clean boot, the CN4 runs this .xml file once and the specified files in the Flash File Store are copied to the CabFiles folder, and then they are run.

## **Installing Applications on the CN4**

You can install files and applications on the computer by using:

- SmartSystems Foundation.
- Microsoft ActiveSync.
- a miniSD card.
- the CN4 FTP server.

For more information on installing applications, see the *Intermec Developer Library Resource Kit Developer's Guide*.

## **Installing Applications Using SmartSystems Foundation Console**

You can use the SmartSystems console to drag-and-drop Intermec applications onto your CN4. The console is part of SmartSystems Foundation. For more information, see “**Managing the CN4 With SmartSystems Foundation**” on page 44.

### **To use SmartSystems console to install an application**

- 1 Download your application file from the Intermec website and unzip it on your desktop PC.

- 2 Double-click the application file to install it. The application file should appear in the Software Vault.
- 3 From the SmartSystems console in the Software Vault, drag-and-drop the application onto each CN4 in your network, or drop the application on a group of CN4s contained in a folder.

You can also use SmartSystems Scan-to-Connect to connect the CN4 to your network and install software. For more information, see the SmartSystems Foundation console online Help.

## Installing Applications Using Microsoft ActiveSync

When you only have a few computers to update with applications, you can copy files using Microsoft ActiveSync.

This procedure assumes that Microsoft ActiveSync is installed on your PC and is up and running. For more information on installing and using ActiveSync, see [“Connecting to a PC” on page 45](#).

### To install an application on the computer using ActiveSync

- 1 Connect to the CN4 via ActiveSync.
- 2 Copy the .cab files from your development PC to the CN4.
- 3 Warm boot or cold boot the CN4.
- 4 After the boot process is finished, browse to the .cab files and tap the files to install them.

## Installing Applications Using a Storage Card

For information on installing the miniSD card in the CN4, see [“Installing a miniSD or SIM Card” on page 37](#).

### To install applications using the storage card

- 1 Copy your application file to the miniSD card.
- 2 Install the miniSD card in the CN4.
- 3 On your CN4, browse to the Storage Card folder and run your application.

## Installing Applications Using the FTP Server

The CN4 has a built-in FTP server that connects to a network through Ethernet, 802.11 b/g, or WAN (Wireless Access Network). You can use the server to transfer your application file to the computer. Because you can create FTP scripts to automate the process of copying files to the computer, this option is useful when you need to send files to a large number of computers.

The easiest way to manage the FTP server is to enable the FTP menu within iConnect.

### To enable the FTP menu

- Create this DWORD registry key and set it to a value of 1:

```
HKEY_CURRENT_USER\Software\iConnect2\iConnect\Settings>ShowFTPMenu
```

The iFTP menu is available the next time you start iConnect.

### To manage the state of the FTP server

- Modify these existing registry keys:

```
HKEY_CURRENT_USER\Software\iConnect2\iConnect\Settings\FtpAutoStart  
HKEY_CURRENT_USER\Software\iConnect2\iConnect\Settings\FtpHeartbeat
```

where 1 = enable and 0 = disable.

## Launching an Application Automatically

There are two ways to automatically launch your application when you perform a reset on the computer:

- Make sure your .cab file places a shortcut to your application in the \Windows\StartUp folder.
- Configure the AutoRun program to launch your application.

The computer contains a program called AutoRun.exe which automates operations such as launching other processes. You can configure AutoRun.exe through the AutoRun data file, AutoRun.dat. For compatibility with other Intermec computers, you can place a copy of AutoRun.exe in the same folder as your AutoRun.dat file but it is not required.

### To create and install the AutoRun.dat file on your computer

- 1 Create a folder called System on your CN4.
- 2 Open the Notepad application on your PC.
- 3 Write commands for AutoRun.dat using the supported AutoRun script commands.
- 4 Save the Notepad file as AutoRun.dat.
- 5 Copy the AutoRun.dat file to the System folder on the CN4. During every boot, the system scans for AutoRun.dat in the System folder.

AutoRun supports the following script commands in AutoRun.dat:

#### AutoRun Script Commands

Command	Description
EXEC	Launches a specified program and waits for it to finish (up to 10 minutes)
CALL	Processes a specified file of commands and returns.
CHAIN	Processes a specified file of commands and does not return.

AutoRun handles quoted file names for the first parameter, which allows you to specify path names or file names that contain white spaces. AutoRun only supports one set of quotes per command.

For more information on AutoRun, see the *Intermec Developer Library Resource Kit Developer's Guide*.

## Integrating Image Capture

The Image Capture application on your CN4 provides a way to capture high-resolution grayscale images. You can integrate Image Capture into your own applications to take advantage of this feature.

### Calling Image Capture From Your Application

To integrate Image Capture features into your existing mobile application, you need to specify two parameters:



- Path to and name of the Image Capture application. Default is “\\Program Files\\Intermec\\ImageCapture\\ImageCapture.exe”.
- Path to and name of the .xml configuration file that Image Capture should use when called by your application. This way you can use a custom .xml configuration file based on your needs. If no .xml file is specified, Image Capture uses its default settings, or looks for an .xml file in its local directory.

This sample code calls Image Capture from its default location and specifies “ImageCapture\_Config.xml” as the custom .xml configuration file to use:

```
try
{
System.Diagnostics.Process.Start("\\ProgramFiles\\ImageCapture
\\ImageCapture.exe", "\\Program Files\\MyApp\\ImageCapture_
Config.xml\\");
}

catch (Exception exception)

{
MessageBox.Show("Failed to execute \\ProgramFiles\\ImageCapture
\\ImageCapture.exe" + "\r\n" + exception.ToString());
}
```

## Creating and Editing the Image Capture XML File

To further customize Image Capture features for use in your application, you can create or edit the Image Capture .xml file. This section lists Image Capture field names, valid values, and descriptions.

### Field Definitions for ImageCapture\_Config.xml

Field Name	Valid Values	Description
<b>Settings</b>		
allowChanges	True or false	Default is true. When set to false, user cannot change any settings.
allowGallery	True or false	Default is true. When set to false, user cannot go to the Gallery screen.

**Field Definitions for ImageCapture\_Config.xml (continued)**

<b>Field Name</b>	<b>Valid Values</b>	<b>Description</b>
<b>Conditioning Settings</b>		
allowChanges	True or false	Default is true. When set to false, user cannot change settings in the Conditioning tab.
<b>Edge Enhancement</b>		
allowChanges	True or false	Default is true. When set to false, user cannot change the edge enhancement setting.
edgeEnhancement	None, low, medium, or high	Default is None. If no value is provided, the edge enhancement value is unchanged.
<b>Lighting Correction</b>		
allowChanges	True or false	Default is true. When set to false, user cannot change the lighting correction setting.
lightingCorrection	True or false	Default is true. If no value is provided, the application cannot change the lighting correction value.
<b>Noise Reduction</b>		
allowChanges	True or false	Default is true. When set to false, user cannot change the noise reduction setting.
noiseReduction	0 to 9	Default is no value. If no value is provided, the application does not change the noise reduction setting.
<b>Image Rotation</b>		
allowChanges	True or false	Default is true. When set to false, user cannot change the rotation setting.
imageRotation	None, 90, 180, 270	Default is no value. If no value is provided, the application does not change the rotation value.
<b>Subsampling</b>		
allowChanges	True or false	Default is true. When set to false, user cannot change the subsampling rate.
subSampling	None, 1:2, 1:3, 1:4, 1:5, 1:6, 1:7, 1:8	Default is no value. If no value is provided, the application does not change the subsampling rate.
<b>Storage Settings</b>		
allowChanges	True or false	Default is false. If set to true, user can change settings in the Storage tab.

**Field Definitions for ImageCapture\_Config.xml (continued)**

Field Name	Valid Values	Description
<b>Image Location</b>		
allowChanges	True or false	Default is false. If set to true, user can change the directory where saved images are stored.
imageLocation	File path	Default is no value. If no value is provided, the application does not change the directory where saved images are stored (My Documents\ ImageCapture).
<b>File Name</b>		
allowChanges	True or false	Default is false. When set to true, user can change the filename template setting.
fileName	String of up to 200 characters	Name to be used for saved image files. If the name is identical to a file already saved, Image Capture adds a numeric character to the end of the file name.
<b>Output Compression</b>		
allowChanges	True or false	Default is false. When set to true, user can change the file format type.
fileFormat	BMP, JPEG	Default is no value. If no value is provided, Image Capture does not change the file format setting. If no format is selected, the file is saved as a .bmp.
<b>Compression Quality</b>		
allowChanges	True or false	Default is false. When set to true, user can change the compression quality setting.
compressionQuality	0% to 100%	Default is no value. If no value is provided, the application does not change the compression quality setting. The higher the value, the better the quality, and the larger the file size will be. If fileFormat is set to BMP, this setting is not used.

### Image Capture XML Example

This XML demonstrates how to use the fields as defined in the previous section.

```
<?xml version="1.0" encoding="utf-8" ?>
<ImageCapture xmlns:xsi="http://www.w3.org/2001/XMLSchema-instance"
xmlns:xsd="http://www.w3.org/2001/XMLSchema">
  <Settings allowChanges ="true" allowGallery="true">
    <Conditioning allowChanges="true">
      <edgeEnhancement allowChanges="true">None</edgeEnhancement>
      <lightingCorrection allowChanges="true">Enabled</lightingCorrection>
      <noiseReduction allowChanges="true">0</noiseReduction>
      <imageRotation allowChanges="true">90</imageRotation>
      <subsampling allowChanges="true">None</subsampling>
    </Conditioning>
    <Storage allowChanges="true">
      <imageLocation allowChanges="false">\My Documents\ImageCapture
</imageLocation>
      <fileName allowChanges="false">
Image_$(num)</fileName>
    </Storage>
  </Settings>
</ImageCapture>
```

## Freeing Up Virtual Memory for Applications

You can use the InstallSelect application to free up virtual memory and create more space to load and run custom applications.



**Note:** InstallSelect is designed for use only by administrators, developers, integrators, or Intermec service representatives.

When you free up virtual memory, you reduce the amount of virtual memory used by portions of the SmartSystems Platform Bundle (SSPB) by removing value-added software features. Be sure to close all other applications and back up any related files before you use InstallSelect. For more information on SSPB, see [“Upgrading the System Software” on page 82](#).



Caution

**Removing software features may result in loss of computer functionality or the ability to manage device settings. Contact your Intermec service representative for information about each software feature before making changes.**

**To free up virtual memory**

- 1 Go to **Start > Programs > File Explorer**.
- 2 Browse to the **Windows** folder and scroll down to find InstallSelect.
- 3 Tap InstallSelect. A Caution message appears, reminding you that removing files may reduce functionality.
- 4 Tap **OK** to clear the message. The InstallSelect screen appears.

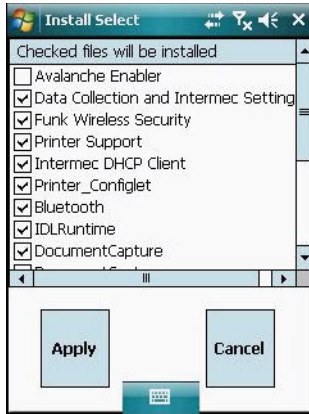

- 5 Clear the check box for each component you do not want installed after a clean boot. For a description of each component, see the next table.
- 6 Tap **Apply** to start the clean boot. A confirming message appears.
- 7 Tap **Yes** to continue. The CN4 performs a clean boot. Only the components you selected are installed.

**InstallSelect Software Components**

Component Name	Description
Avalanche Enabler	Enables the client to the Wavelink Device Management solution.
Data Collection & Intermec Settings	Enables data collection components, including the scanner and decode engines, and Intermec Settings. Also includes on-unit SDK libraries.
Funk Wireless Security	Intermec security supplicant that provides a wireless security solution with several features that are not supported by Microsoft.

**InstallSelect Software Components (continued)**

Component Name	Description
Printer Support	Provides Intermec printer driver support.
Intermec DHCP Client	Provides the Intermec DHCP client application.
Printer_Configlet	Intermec Settings configuration support for Bluetooth printers.
Bluetooth	Intermec Bluetooth integration support.
IDLRuntime	Runtime files supporting the Data Collection and Device Resource Kits.
Document Imaging	Enhanced Mobile Document Imaging components. Supported by CN4s with the EA21 area imager.
Image Capture	Image Capture application and components. Supported by CN4s with the EA21 area imager.
Power Profiler	Power Profiler applet.
GPS Applet	iGPS Settings applet.
Additional Files	Microsoft C Runtime Library

Depending on the options installed in your CN4, you may see other components available from the InstallSelect application.

## Upgrading the System Software

When you upgrade your computer, you are updating the operating system (OS) and the SmartSystems Platform Bundle (SSPB) files.

You can choose to upgrade only the operating system. If you upgrade only the operating system, you will need to reinstall the SSPB files.

SSPB files are stored in the Flash File Store and deliver Intermec value-add (IVA) functionality such as data collection, configuration, Intermec Bluetooth integration, the Intermec wireless security suite, and the SmartSystems Reference Client. As new features are added to these components, you can update your SSPB files without updating the operating system.

If you have any SRs (service releases) that you want to install, you can copy them to this directory:

- \Flash File Store\SSPB\SRS

There are two ways to upgrade your computer:

- You can upgrade your computer using the SmartSystems console. For help, see **“Upgrading the CN4 Using SmartSystems Foundation” on page 84.**
- You can upgrade your computer using a storage card. For help, see **“Upgrading the CN4 Using a miniSD Card” on page 85.**

## **Locating Upgrade Files**

Before you can upgrade, you need to download the latest upgrade files from the Intermec website to your desktop PC.

### **To download the upgrade files**

- 1** Open a web browser and go to **[www.intermec.com](http://www.intermec.com)**.
- 2** Choose **Support > Downloads** and choose these items:
  - a** In the **Product Category** list, choose **Computers**.
  - b** In the **Product Family** list, choose **Handheld Computers**.
  - c** In the **Product** list, choose **CN4 Mobile Computer**.
- 3** Click **Submit**. A list of downloadable software appears.
- 4** Look for the appropriate upgrade files in the OS/Firmware/Drivers list, and click a filename to download it.

If you are managing the CN4 with SmartSystems Foundation, Intermec Update alerts you when new upgrades or software are available. You can have the upgrades and software installed to the console for immediate use. For information, see **“Managing the CN4 With SmartSystems Foundation” on page 44.**

## Upgrading the CN4 Using SmartSystems Foundation

You can use the SmartSystems Foundation console to upgrade the operating system on your CN4. For information on using SmartSystems Foundation, see “[Managing the CN4 With SmartSystems Foundation](#)” on page 44.

### To upgrade the CN4 using SmartSystems Foundation

- 1 On your desktop PC, open the SmartSystems console.
- 2 Make sure the SmartSystems console and the CN4 are on the same subnet.
- 3 Make sure the CN4 is either in a communications dock or charging dock, or the device power management is disabled.
- 4 Download the device upgrade file to your PC as described in the previous section, “Locating Upgrade Files.”
- 5 Double-click the .exe file on your PC. An InstallShield application starts and walks you through the process of extracting the upgrade files to the default location.



**Note:** Do not change the default location where InstallShield extract the files. The SmartSystems console requires the files to be in this location.

- 6 From the SmartSystems console, locate the device upgrade to install.
- 7 Drag the file to each CN4 you want to upgrade or to a group of CN4s in a folder. The SmartSystems console installs the upgrade on your computers.

After the download is complete, your CN4 replaces the operating system and automatically performs a cold boot.



**Note:** The SmartSystems console displays a red stop sign symbol, indicating that the CN4 is offline, until the CN4 reboots and reconnects to the system.



## Upgrading the CN4 Using a miniSD Card

To use a miniSD card to upgrade the computer, you need an SD card reader and a miniSD adapter card formatted as FAT16.

### To upgrade the operating system using a miniSD card

- 1 Copy all required OS upgrade files to the miniSD card.
- 2 Insert the miniSD card into the CN4. For help, see **“Installing a miniSD or SIM Card” on page 37**.
- 3 Place the CN4 in a dock connected to external power and use a stylus to press the **Reset** button located in the battery cavity on the back of the CN4. For help, see **“Cold Booting the CN4” on page 98**.
- 4 Remove the miniSD card when the Installation Complete menu appears.
- 5 Remove the CN4 from the dock and replace the battery.

### To upgrade the SSPB using a miniSD card

- 1 Copy all required SSPB upgrade files to the miniSD card.
- 2 Insert the miniSD card into the CN4.
- 3 Clean boot the CN4. For help, see **“Clean Booting the CN4” on page 99**. When the clean boot is complete, the CN4 warm boots to reset the configuration.
- 4 (Optional) Remove the miniSD card or delete the files on the miniSD card. During the clean boot, the files were copied from the miniSD card to the Flash File Store.
- 5 Set the network communication parameters to reestablish communications with the other devices in the wireless network.



# 4

## Troubleshooting and Maintaining the CN4

If you encounter any problems while using the CN4, look in this chapter to find a possible solution. You will also find information on routine maintenance. This chapter contains these sections:

- **Calling Product Support**
- **Troubleshooting the CN4**
- **Resetting the CN4**
- **Cleaning the CN4**

## Calling Product Support

If you cannot find the answer to your problem in the **Troubleshooting the CN4** section, you can visit the Intermec technical knowledge base (Knowledge Central) at [intermec.custhelp.com](http://intermec.custhelp.com) to review technical information or to request technical support. If you still need help after visiting Knowledge Central, you may need to call Product Support.

To talk to an Intermec Product Support representative, call:

**1-800-755-5505**

Before you call Intermec Product Support, make sure you have the following information ready:

- Configuration number
- Serial number
- Operating system version
- SmartSystems Platform Bundle (SSPB) version
- Power management settings
- If you are using security, know the type (Funk or Microsoft) and the full set of parameters
- If you are using terminal emulation (TE), know the version and protocol. If you are not using TE, know the language your custom application was written in and the tools you used to create it.

You can find most of the information listed above in Intermec Settings. Consult your application developer for information on your custom application.

### **To find your configuration number**

- Look at the label on the back of the computer.

**To find your operating system version**

- 1 Tap **Start > Internet Explorer**.
- 2 Tap the **Intermec** logo. The Intermec page appears and displays the software build information.

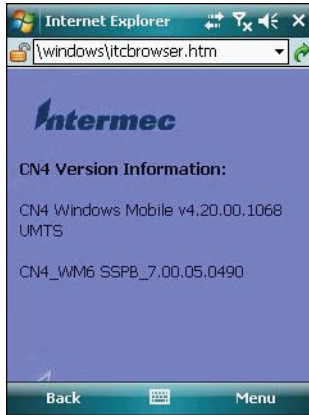

## Troubleshooting the CN4

If you send the CN4 in for service, it is your responsibility to save the computer data and configuration. Intermec is responsible only for ensuring that the hardware matches the original configuration when repairing or replacing the computer.

### Problems While Configuring the CN4

Problem	Solution
You scan a configuration command, such as Beeper Volume, and you hear three low beeps.	If you are working in Intermec Settings, you cannot scan configuration commands. Exit the application to scan configuration commands.
You scan or enter an option for the Scanner Model configuration command and you hear three low beeps.	You may have scanned or entered a Scanner Model command that does not apply to the type of scanner that you have installed. Try scanning or entering the Scanner Model command again and select an option for the type of device you are using.
You cannot type a character on the keypad or you can only type uppercase or lowercase letters.	You may have locked a modifier key on the keypad. Press the necessary key sequence to unlock the key. For help, see <a href="#">“Using the Keypad” on page 12</a> .

## Chapter 4 – Troubleshooting and Maintaining the CN4

### Problems While Operating the CN4

Problem	Solution
You press the <b>Power</b> button and nothing happens.	<ul style="list-style-type: none"><li>• Make sure the backlight is on.</li><li>• Make sure you have a charged battery that is installed correctly. For help, see <b>“Charging the Battery” on page 4</b>.</li><li>• Replace the battery with a charged battery. For help, see <b>“Charging the Battery” on page 4</b>.</li><li>• Perform a warm boot or a cold boot. For help, see <b>“Resetting the CN4” on page 97</b>.</li></ul>
The Battery status LED is on.	<p>The battery status LED indicates the following states:</p> <ul style="list-style-type: none"><li>• If the battery status LED is a steady green, the battery is more than 95% charged and computer is on a charger.</li><li>• If the battery status LED is blinking red, then the battery is low. Replace or charge the battery.</li><li>• If the battery status LED is a steady red, the main battery is on charge.</li><li>• If the battery status LED is amber, the CN4 is on charge and either the battery temperature is outside of the charging range, or the battery is defective.</li></ul>
The computer appears to be locked up and you cannot enter data.	<ul style="list-style-type: none"><li>• Press the power key to turn off the computer, then press the power key again to turn it on.</li><li>• Press and hold the power key ten seconds to warm boot the computer.</li><li>• Try reloading the firmware. See <b>“Freeing Up Virtual Memory for Applications” on page 80</b>.</li><li>• If the computer does not boot or reset, contact your Intermec representative for help.</li></ul>
You tap the screen and nothing happens.	Align your screen. For help, see <b>“Aligning the Touch Screen” on page 21</b> .

### Problems With 802.11 Network Connectivity

Problem	Solution
When you turn on the computer after it was suspended for a while (10 to 15 minutes or longer), it can no longer send or receive messages over the network.	Host may have deactivated or lost current terminal emulation session. In a TCP/IP direct connect network, turn off the “Keep Alive” message from host to maintain the TCP session while the computer is suspended.

**Problems With 802.11 Network Connectivity (continued)**

Problem	Solution
The CN4 is connected to the network and you move to a new site to collect data. Your CN4 now shows you are not connected to the network.	Move closer to an access point or to a different location to reestablish communications until you reconnect with the network. Any data collected while out of range is transmitted over the network.
The CN4 appears to be connected to the network, but you cannot establish a terminal emulation session with the host computer.	There may be a problem with the host computer, with the connection between the Intermec Application Server and the host computer, or with the connection between the access point and the host computer. Check with network administrator to make sure the host is running and allowing users to login to the system.
The CN4 appears to be connected to the network, but the host computer is not receiving any information from the CN4.	In a TCP/IP network, there may be a problem with the connection between the access point and the host computer. Check with network administrator or use your access point user’s manual.

**Problems While Configuring 802.1x Security**

Problem	Solution
The CN4 indicates that it is authenticated, but it does not communicate with the host.	Make sure the CN4 IP address, host IP address, subnet mask, default router are configured for network.
The CN4 does not appear to be authenticating and a network connection icon does not appear on the toolbar.	The CN4 may not be communicating with the access point. Make sure the CN4 network name matches the access point network name (SSID). 802.1x security network may not be active. Make sure the server software is properly loaded and configured on the server PC. See server software documentation for help.
A network connection icon appears in the toolbar, but then disappears.	The CN4 may not be communicating with the intended access point. Make sure the CN4 network name matches the access point network name. Default network name is “INTERMEC.” Access point may not be communicating with server. Ensure the access point is turned on, properly configured, and has 802.1x security enabled
You are setting up multiple access points in a network, with different SSIDs, and the connection fails.	The CN4 does not save WEP key values when changing the SSID. Reenter the WEP key value after changing the SSID and save your changes. You should now be able to connect to the different access points.

### Problems While Configuring 802.1x Security (continued)

Problem	Solution
The CN4 indicates it is not authenticated.	Make sure that: <ul style="list-style-type: none"><li>• the User Name and Password parameters on the CN4 must match the user name and password on authentication server. You may need to reenter the password on both the CN4, authentication server.</li><li>• on your authentication server, the user and group are allowed and the group policy is allowed to log into the server. For help, see the documentation that shipped with your authentication server software.</li><li>• the IP address and secret key for access point must match the IP address and secret key on the authentication server. You may need to reenter the IP address and secret key on both your access point and authentication server.</li><li>• the authentication server software is running on the server PC.</li></ul>
You receive a message saying “The server certificate has expired or your system date is incorrect” after you perform a clean boot on the CN4.	Date and time are not saved when you perform a clean boot. Reenter the date and time, and then save your changes.

### Problems Reading Bar Codes

Problem	Solution
You cannot see a red beam of light from the imager when you press the <b>Scan</b> button and aim the imager at a bar code label.	<ul style="list-style-type: none"><li>• You may be too far away from the bar code label. Try moving closer to the bar code label and scan it again.</li><li>• You may be reading the bar code label “straight on.” Change the reading angle and try again.</li><li>• The imager hardware trigger might be disabled in Intermec Settings. To check the setting go to <b>Start &gt; Settings &gt; System Tab &gt; Data Collection &gt; Scanner Settings</b>. Hardware trigger should be checked.</li></ul>
The input device attached to the computer does not work well or read bar code labels very quickly.	Set the Scanner Model command to the specific attached input device. Check enabled bar code symbologies and enable only the symbologies being used.



**Problems Reading Bar Codes (continued)**

Problem	Solution
When you release a <b>Scan</b> button or handle trigger, the <b>Good Read</b> light does not turn off.	The <b>Good Read</b> light will remain on if you configure the computer to use continuous/edge triggering. If you configure the computer for level triggering and the <b>Good Read</b> light remains on, there may be a problem. Press one of the <b>Scan</b> buttons or pull the trigger again without scanning a bar code label. If the light is still on, contact your local Intermec representative.
The scanner will not read the bar code label.	<ul style="list-style-type: none"> <li>• Aim the scanner beam to cross entire bar code label in one pass. Vary the scanning angle.</li> <li>• Check the quality of the bar code label, Scan a bar code label that you know will scan. Compare the two bar code labels to see if the bar code quality is too low. You may need to replace the label that you cannot scan.</li> <li>• Make sure the bar code symbology is enabled and configured correctly. Use Intermec Settings to check the symbologies. Expand <b>Data Collection &gt; Symbologies</b> beneath devices listed (scanner, virtual wedge) to check and enable symbologies, then scan the bar code label again.</li> <li>• Make sure the computer application is expecting input from a bar code. You may need to type this information instead.</li> </ul>
The scanner does not read the bar code labels quickly, or the scanning beam seems to be faint or obscured.	The scanner window may be dirty. Clean the window with a solution of ammonia and water. Wipe dry. Do not allow abrasive material to touch the window.
You scan a valid bar code label to enter data for your application. The data decoded by the scan module does not match the data encoded in the bar code label.	The computer may have decoded the bar code label in a symbology other than the label's actual symbology. Try scanning the bar code label again. Make sure you scan the entire label.

## Checking 802.11 Network Status

If you have trouble connecting to your 802.11 wireless network:

- Make sure you have correctly set network parameters on the CN4.
- Check your wireless security settings.

Follow the next procedure to use iConnect to verify available access points and networks, check signal strength, and view other diagnostics. If you need to contact Intermec Product Support, this information can be helpful in troubleshooting wireless network connection issues.

### To use iConnect to verify network status

- 1 Tap the iConnect icon (  ) in the lower right corner of the CN4 screen.
- 2 Choose **Status** > **Wireless**.
- 3 Tap **Advanced**. The diagnostics screen appears.

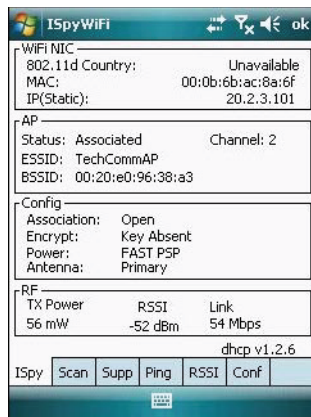

The ISpy tab shows:

- MAC address and IP address of the 802.11 radio.
- network association status, including the SSID and MAC address of the access point
- security configuration.
- radio transmit power and signal strength information.

- 4 Tap the **Scan** tab to view a list of available 802.11 networks. The list includes the signal strength, channel, and MAC address for each network.

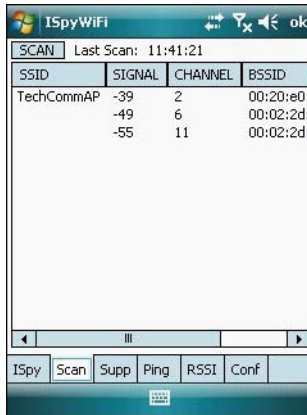

- Tap **Scan** to refresh the screen.
- 5 Tap the **Supp** tab to view radio supplicant information, including a list of supplicant events and authentication status.



- To verify the settings for the currently active security profile, tap **Configure Profile**. The Profile Wizard for the active profile appears.
- To try reconnecting to the network, tap **Reconnect**.
- To delete the events in the list, tap **Clear Events**.

- 6 Tap the **Ping** tab to run a ping test to the host.

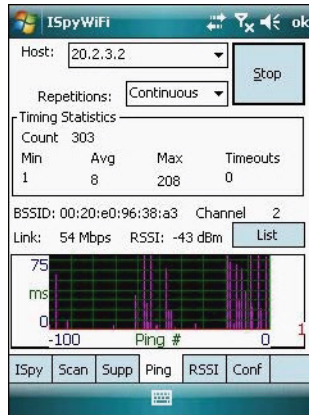

To run a ping test:

- a In the **Host** field, enter the IP address of the host.
  - b From the **Repetitions** list, choose the number of times the CN4 will ping the host.
  - c Tap **Ping**. The graph shows the amount of time it takes for the host to return the ping. Tap **List** to see this information in a list format.
- 7 Tap the **RSSI** tab to view the received signal strength of the host signal.

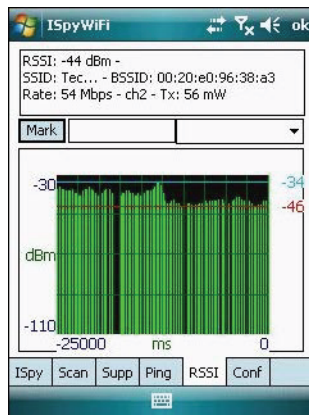

The information box includes the current signal strength, host SSID name, MAC address, data rate, and transmit power.

- Tap Mark to place an arrow marker above the graph.
- 8** Tap the **Conf** tab to set up a log file that lists RSSI history.

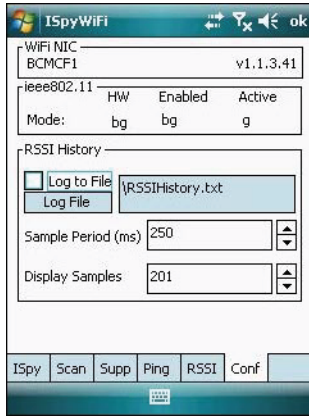

This screen includes the 802.11 radio driver version and available radio modes.

To create a log file:

- a** Check the **Log to File** check box.
- b** (Optional) Change the sample period and number of samples displayed.
- c** Tap **Log File**. The Save As screen appears.
- d** (Optional) Change the name of the saved log file, the folder to which the file will be saved, the content type (log or text), and the location.
- e** Tap **Save**.

## Resetting the CN4

You rarely need to reset the computer. If the computer does not resume after pressing the **Power** button, or if the computer or an application locks up, you may need to reset the CN4. The CN4 uses the configuration currently saved in flash memory during the boot process. There are three ways to reset the CN4:

- Warm booting the CN4
- Cold booting the CN4

- Clean booting the CN4

## **Warm Booting the CN4**

You may need to perform a warm boot to correct conditions where an application stops responding to the system.

### **To warm boot the computer**

- Press and hold the **Power** button for 10 seconds.
- Or,
- Right-click on the CN4 via the SmartSystems console and select **Intermec Power Tools > Warm Boot Device**.

The computer systematically shuts down, restarts, and goes through the initialization process.

## **Cold Booting the CN4**

In some cases where the computer completely stops responding, you may need to perform a cold boot. Because cold booting may result in data loss, use this method only if all other recovery methods have failed.



**Note:** Cold booting the CN4 does not guarantee that cached disk data will be saved, so transactional data may be lost during the reset. All other data, such as CN4 configuration and network settings, is preserved.

### **To cold boot your CN4**

- 1** Press the **Power** button to suspend the CN4.
- 2** Remove the battery pack from the CN4.
- 3** Use the stylus to press the **Reset** button on the back of the CN4.

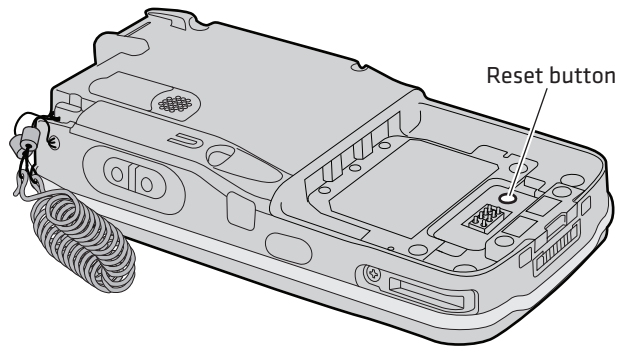

**Locating the Reset Button on the CN4**

## Clean Booting the CN4



Caution

A clean boot erases the memory in the mobile computer, including all applications and data files found in the ObjectStore, and loads only the default files and programs required by the CN4 operating system.



Caution

During a clean boot, the CN4 first looks for the SSPB files on an installed miniSD card. If no card is found, the CN4 loads the SSPB files in the Flash File Store. Files found on a miniSD card during a clean boot are copied into the Flash File Store and overwrite the existing SSPB files.

If the CN4 seems to be locked up, try warm booting and then cold booting the computer. If neither method works, use a clean boot to get the CN4 up and running for further troubleshooting.

The clean boot process is as follows:

- initial boot > SSPB installation > reboot > DCE installation > SRs copied to CabFiles folder > \_sstransferagent.xml run > reboot > CabFiles folder contents run > reboot, if required.

### To clean boot the computer

- 1 Press the **Power** button to suspend the CN4.
- 2 Remove the battery pack from the back of the CN4.
- 3 Use the stylus to press the **Reset** button on the back of the CN4.

- 4 Insert the battery pack into the CN4, and immediately press and hold the **Power** button and both buttons on the left side.
- 5 Continue to hold the **Power** button and both buttons on the left side until a Warning message appears on the display.
- 6 Release the **Power** button and both buttons on the left side, read the message, and press either button on the right side to continue.
- 7 Wait for the CN4 to load files from its ROM.



**Note:** You can also clean boot the CN4 using the SmartSystems console. To clean boot the CN4 using the SmartSystems console, right-click the CN4 and select **Intermec Power Tools > Clean Boot Device**.

## Cleaning the CN4

To keep the CN4 in good working order, you may need to clean the imager window, color camera window, and the touch screen. Clean the windows and the touch screen as often as needed for the environment in which you are using the CN4. To clean the CN4, use a solution of ammonia and water.



Caution

**There are no user-serviceable parts inside the CN4. Opening the CN4 will void the warranty and may cause damage to the internal components.**

### **To clean the imager window, camera window, and touch screen**

- 1 Press the **Power** button to suspend the CN4.
- 2 Dip a clean cloth towel in the ammonia solution and wring out the excess.
- 3 Wipe off the imager window, camera lens, and flash area. Do not allow any abrasive material to touch these surfaces.
- 4 Wipe dry.



# A

## Specifications and Default Settings

# Physical and Environmental Specifications

## **CN4 Physical Dimensions** (excluding overmold)

Length: 17.3 cm (6.8 in)

Width: 8.1 cm (3.2 in)

Height: 2.8 cm (1.1 in) with standard battery

3.3 cm (1.3 in) with extended battery

Weight: 397 to 454 g standard battery (14 to 16 oz)

## **CN4e Physical Dimensions** (excluding overmold)

Length: 21.0 cm (8.3 in)

Width: 8.1 cm (3.2 in)

Height: 3.3 cm (1.3 in) with extended battery

Weight: 510 to 567 g (18 to 20 oz)

## **Hardware**

Microprocessor: Marvell PXA270M

Application processor: 520 MHz RAM

Memory: 128 MB RAM

Persistent storage: 256 MB NAND flash, provides onboard non-volatile storage

Removable storage: miniSD card slot, user-accessible

Keypad: numeric, QWERTY (CN4), alphabetic (CN4e)

Imaging options: EA11 area imager, EA21 area imager, or color camera

**Bluetooth QD ID:** B013037

## **Operating System**

Microsoft Windows Mobile 6.1

## **Standard Communications**

Ethernet, Serial, IRDA, USB host, USB client, Bluetooth, 802.11 b/g, 802.11 d, HSDPA, UMTS, CDMA, GPS

### **Touch Screen Specifications**

Transflective TFT; QVGA color with touch panel; 240 x 320 pixels; 8.9 cm (3.5 in) diagonal active area; 5-level LED backlight control with settings

### **Electrical Specifications**

External charge power: 5 V +/- 5% @3.5 A max (18 W max)

### **Environmental**

Operating temperature: -20 °C to 60 °C (-4 °F to 140 °F)

Storage temperature: -20 °C to 70 °C (-4 °F to 158 °F)

Humidity: 5% to 95% non-condensing

Rain and dust resistance: IP64 compliant

Drop specifications: 26x all faces, sides, and corners from 1.8 m (6 ft) per MIL-STD 810G

### **Power Specifications**

Battery type: Rechargeable Lithium-Ion (Li-ion) batteries:

AB8, AB15: 3.7 VDC, 2.2 Ah

AB9, AB16, AB28: 3.7 VDC, 4.0 Ah

Recharge time: 5 hours or less

Recharge temperature: 0 °C to 40 °C (32 °F to 104 °F)

Battery capacity: AB8, AB15: 8 Wh

AB9, AB16, AB28: 14 Wh

Backup battery: Super capacitor supplies 5 minutes bridge time

### **Wireless LAN**

Standards compliant: IEEE 802.11g (2.4 GHz, OFDM)

IEEE 802.11 b (2.4 GHz, DSSS)

Data rates: Up to 54 Mbps for 802.11g

Up to 11 Mbps for 802.11b

Radio power output: 100 mW

Security: WPA2, WPA, 802.11i, 802.1x, WEP (EAP-TLS, TTLS, LEAP, PEAP, EAP-FAST)

Certifications: WPA2, WPA, Wi-Fi, Cisco Compatible Extensions (CCX) version 4

**Regulatory Approvals**

Safety: cULus Listed, GS, CCC, GOST (pending), NOM, HKSI

EMC: FCC Part 15B – Class B, ICES-003 Class B, EN 55022 Class B, EN 55024, EN 301 489-17, AS/ZNS 3548, GB9254-1998, BSMI, ICASA

Radio: FCC Part 15.247, Industry Canada RSS 210, EN 300 328-2, Telecom. Num. 547, NCC, OFTA, MIC, IDA

Other: Compliant with all applicable EU Directives – EMC, Low Voltage, R&TTE, Vehicle, WEEE, RoHS, Packaging & Waste Packaging

Hazardous Location Certified:

UL Listing (United States and Canada)

- Division 2, Class I, Groups A, B, C, D; T4
- Division 2, Class II, Groups F; G T4
- Division 2, Class III; T4

### EA21 Area Imager Typical Reading Distances

Typical distances are measured in an office environment (250 lux).

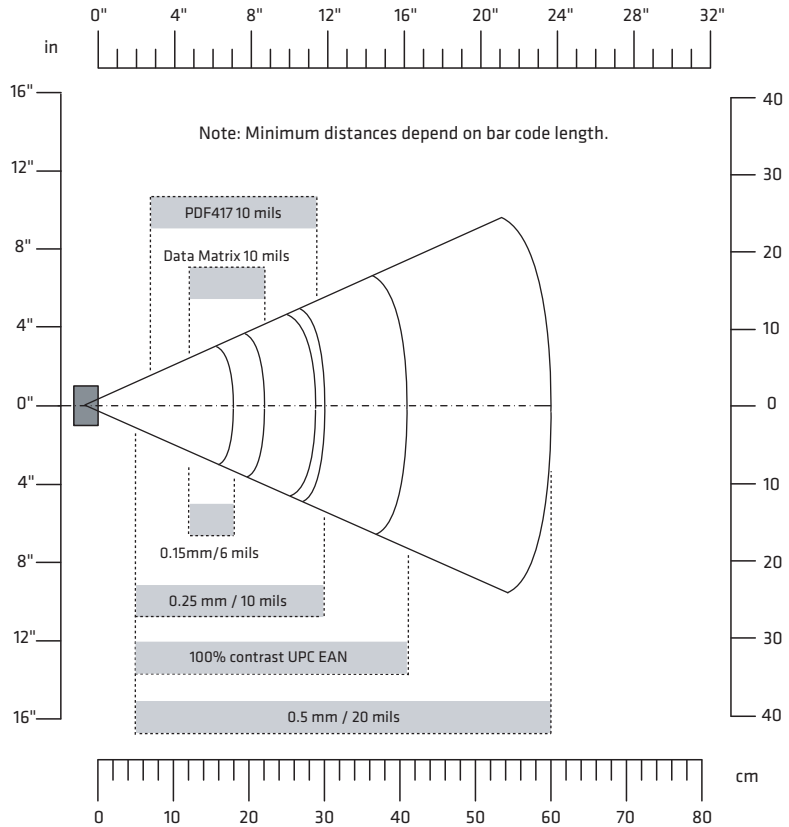

### EA21 Typical Reading Distances

Symbology	Density	Minimum Distance	Maximum Distance
Code 39	0.15 mm (6 mil)	12 cm (4.72 in)	18 cm (7.09 in)
	0.25 mm (10 mil)	5 cm (1.97 in)	30 cm (11.81 in)
	0.5 mm (20 mil)	5 cm (1.97 in)	60 cm (23.62 in)
	1 mm (40 mil)	9 cm (3.54 in)	95 cm (37.40 in)
UPC/EAN 100%	0.33 mm (13 mils)	5 cm (1.97 in)	41 cm (16.14 in)
Data Matrix	0.25 mm (10 mils)	12 cm (4.72 in)	22 cm (8.66 in)
	0.38 mm (15 mils)	8 cm (3.15 in)	35 cm (13.78 in)
PDF417	0.25 mm (10 mils)	7 cm (2.75 in)	29 cm (11.42 in)
	0.38 mm (15 mils)	7 cm (2.75 in)	44 cm (17.32 in)

**EA21 Area Imager Minimum Reading Distances**

Minimum distances are measured in the dark (0 lux).

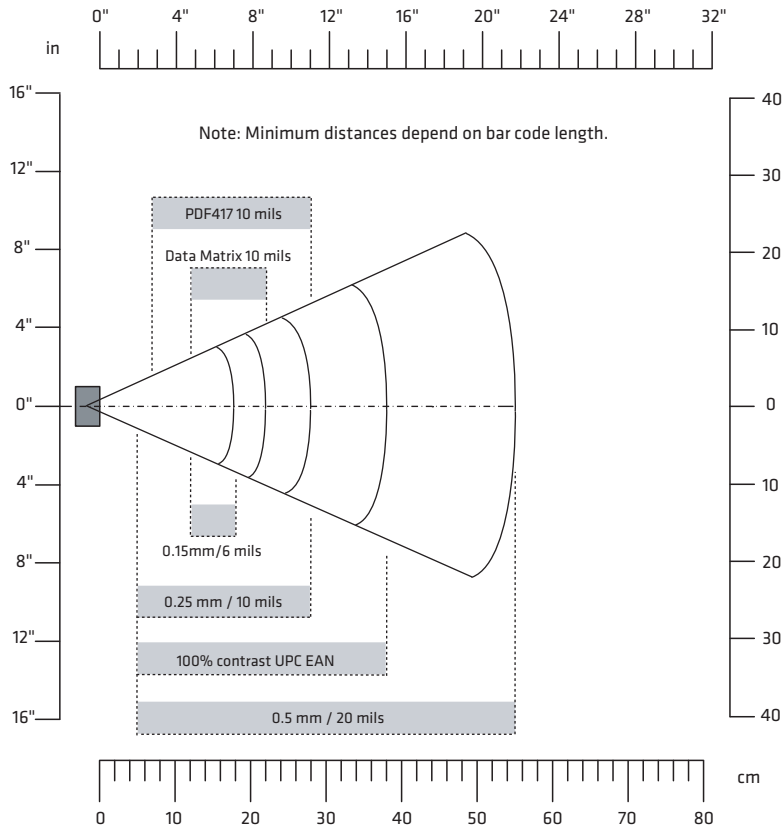

**EA21 Minimum Reading Distances**

Symbology	Density	Minimum Distance	Maximum Distance
Code 39	0.15 mm (6 mil)	12 cm (4.72 in)	18 cm (7.09 in)
	0.25 mm (10 mil)	5 cm (1.97 in)	28 cm (11.02 in)
	0.5 mm (20 mil)	5 cm (1.97 in)	55 cm (21.65 in)
	1 mm (40 mil)	9 cm (3.54 in)	75 cm (29.53 in)
UPC/EAN 100%	0.33 mm (13 mils)	5 cm (1.97 in)	38 cm (14.96 in)
Data Matrix	0.25 mm (10 mils)	12 cm (4.72 in)	22 cm (8.66 in)
	0.38 mm (15 mils)	8 cm (3.15 in)	34 cm (13.39 in)
PDF417	0.25 mm (10 mils)	7 cm (2.75 in)	28 cm (11.02 in)
	0.38 mm (15 mils)	7 cm (2.75 in)	40 cm (15.75 in)

### EA11 Area Imager Typical Reading Distances

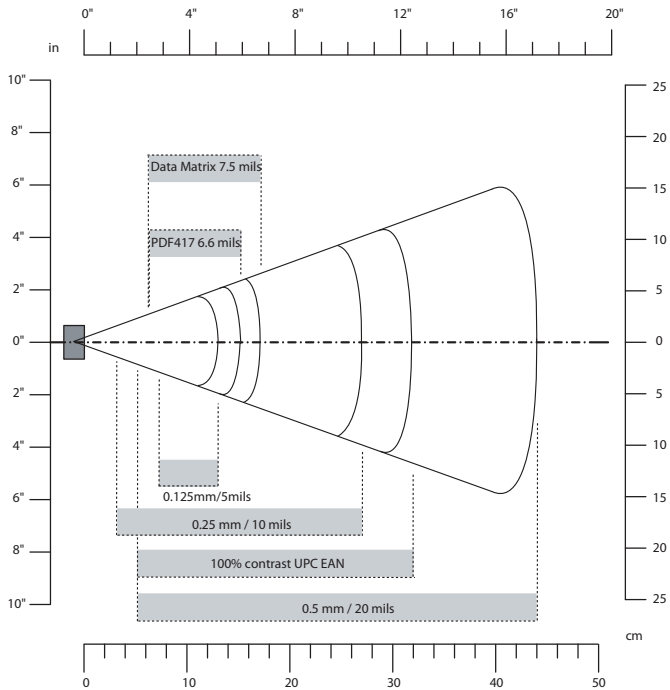

### EA11 Typical Reading Distances

Symbology	Density	Minimum Distance	Maximum Distance
Code 39	0.125 mm (5 mil)	7.2 cm (2.8 in)	13.1 cm (5.1 in)
	0.20 mm (8 mil)	3.8 cm (1.5 in)	22.5 cm (8.8 in)
	0.25 mm (10 mil)	3.4 cm (1.3 in)	27 cm (10.5 in)
	0.50 mm (20 mil)	5 cm (2 in)	44 cm (17.2 in)
	1 mm (40 mil)	8 cm (3.1 in)	83 cm (32.4 in)
UPC/EAN	0.33 mm (13 mils)	5 cm (2 in)	32 cm (12.5 in)
Data Matrix	0.191 mm (7.5 mils)	6.3 cm (2.5 in)	17.3 cm (6.7 in)
	0.254 mm (10 mils)	4.8 cm (1.9 in)	22 cm (8.6 in)
	0.381 mm (15 mils)	*	29 cm (11.3 in)
PDF417	0.168 mm (6.6 mils)	6.25 cm (2.46 in)	15.4 cm (6 in)
	0.254 mm (10 mils)	4.5 cm (1.8 in)	23 cm (9 in)
	0.381 mm (15 mils)	4 cm (1.6 in)	37 cm (14.4 in)

**EA11 Area Imager Minimum Reading Distances**

Minimum distances are measured in the dark (0 lux).

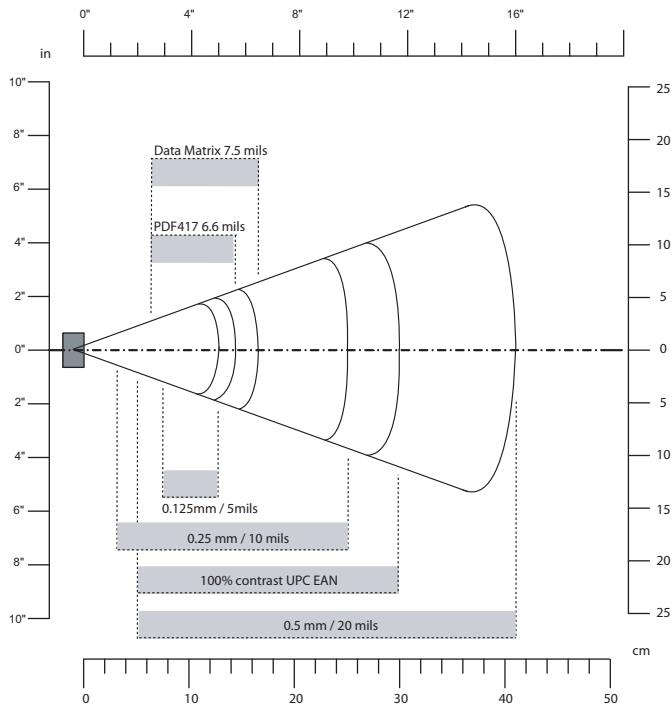

**EA11 Minimum Reading Distances**

Symbology	Density	Minimum Distance	Maximum Distance
Code 39	0.125 mm (5 mil)	7.26 cm (2.86 in)	12.09 cm (4.76 in)
	0.20 mm (8 mil)	3.96 cm (1.56 in)	20.98 cm (8.26 in)
	0.25 mm (10 mil)	3.45 cm (1.36 in)	25.04 cm (9.86 in)
	0.50 mm (20 mil)	4.98 cm (1.96 in)	40.28 cm (15.86 in)
UPC/EAN	0.33 mm (13 mils)	4.98 cm (1.96 in)	29.62 cm (11.66 in)
Data Matrix	0.191 mm (7.5 mils)	3.71 cm (2.46 in)	16.41 cm (6.46 in)
	0.254 mm (10 mils)	5.98 cm (2.35 in)	20.73 cm (8.16 in)
	0.381 mm (15 mils)	*	27.58 cm (10.86 in)
PDF417	0.168 mm (6.6 mils)	6.25 cm (2.46 in)	13.87 cm (5.46 in)
	0.254 mm (10 mils)	4.47 cm (1.76 in)	21.74 cm (8.56 in)
	0.381 mm (15 mils)	4.98 cm (1.96 in)	33.43 cm (13.16 in)



# Accessories

All of the accessories listed below work for both the CN4 and CN4e models unless otherwise noted.

## **AA15 Audio Adapter**

Use the audio adapter to connect your audio headset to the CN4.

## **AA16 Ethernet Adapter**

Use the Ethernet adapter to connect the CN4 to your Ethernet network without using a dock.

## **AA17 RS-232/DEX Adapter**

Use the RS-232/DEX adapter to enable the CN4 to receive serial communications.

## **AA18 USB Adapter**

Use the USB adapter to connect the CN4 to USB.

## **AC14 Quad Battery Charger**

Use the quad battery charger to charge up to four CN4 battery packs.

## **AD10 Single Dock**

Use the single dock to hold a CN4 with its battery installed, charge a spare battery pack, charge the main battery pack, and provide power to the CN4. The dock has USB host and client connectors. Optional modules are available to convert the USB host to Ethernet or to a landline modem.

## **AD11 Multidock**

Use the multidock to hold up to four CN4s with batteries installed. The multidock charges the batteries and provides power and Ethernet connections to each CN4.

## **AD12 Charge-Only Multidock**

Use the charge-only multidock to hold up to four CN4s with batteries installed, charge batteries, and provide power to CN4s.

## **AE11 Vehicle Power Adapter**

Use the vehicle power adapter to charge the CN4 in your vehicle.

### AR1 Magnetic Card Reader

The magnetic card reader provides magnetic stripe reading capability to the CN4.

### AV6 Vehicle Dock

Use the vehicle dock to hold and charge the CN4 while using it on a vehicle.

### AV9 Vehicle Dock

Use the vehicle dock to hold and charge the CN4e while using it on a vehicle.

### CN4 Scan Handle

Use the scan handle to provide better ergonomics for higher-volume scanning applications.

## Default Settings

The following tables list the default values of the configuration settings supported on the CN4. If you restore the CN4 to factory default settings, the CN4 uses these values.

The settings are grouped by function and reflect the organization of Intermec Settings. For detailed information on most of the commands, see the *Intermec Settings Command Reference Manual*, available from the Intermec website at [www.intermec.com](http://www.intermec.com).

### Data Collection

Data Collection Setting	Default Value
Enable scanner port	Enable
Enable scanner auto-detect	Enable

Symbology	Default Value
AustraliaPost	Disable
Aztec	Disable
BPO	Disable
CanadaPost	Disable

<b>Symbology (continued)</b>	<b>Default Value</b>
ChinaPost	Disable
Codabar	Disable
Codablock A	Disable
Codablock F	Disable
Code 11	Disable
Code 39	Enable
Code 93	Disable
Code 128/GS1-128	Enable
DataMatrix	Enable
DutchPost	Disable
EAN/UPC	Enable UPC A, UPC E, EAN 8, EAN 13
EAN.UCC Composite	Disable
GS1 DataBar Expanded	Disable
GS1 DataBar Limited	Disable
GS1 DataBar Omni-Directional	Disable
Interleaved 2 of 5	Disable
JapanPost	Disable
Matrix 2 of 5	Disable
Maxicode	Disable
Micro PDF417	Disable
MSI	Disable
PDF417	Enable
Planet	Disable
Plessey	Disable
Postnet	Disable
QR Code	Disable
Standard 2 of 5	Disable
Telepen	Disable
TLC 39	Disable

## Appendix A – Specifications and Default Settings

Symbology Option	Default Value
Preamble	None (disabled)
Postamble	None (disabled)
Global Symbology ID	Disable

Scanner Setting	Default Value
Hardware Trigger	Enable
Turn Off After Good Read	Enable/One-shot
Trigger mode (area imagers only)	Level

Imager Setting	Default Value
Predefined Modes	1D and 2D Standard
Sticky aimer LED duration	0 (disabled)
Signature Image Capture	Disable

Decode Security Setting	Default Value
Consecutive Data Validation	0
Identical Consecutive Timeout	300 ms
Different Consecutive Timeout	0
Center Decoding	Disable
Center Decoding Tolerance	Disable

Virtual Wedge Setting	Default Value
Virtual Wedge	Enable
Grid	Null

## Communications

Communication Setting	Default Value
Security Choice	Funk
Allow Security Changes	Enabled
Active Profile	Profile 1
DHCP	Enabled
Import Root Certificates	False
Import User Certificates	False
Import Pac Files	False
Radio Measurement	250
Radio	Enabled
Ethernet Adapter IP Settings	DHCP
Bluetooth Power	Off
Bluetooth Discoverable	Disabled
Bluetooth Connectable	Enabled

## Device Settings

Device Settings	Default Value
Adjust for Daylight Time	Off
Scanner Beep	One beep
Scanner Good Read Light	On
Tethered Scanner Beep	One beep
Tethered Scanner Good Read Light	On
Bluetooth Scanner Beep	One beep
Bluetooth Scanner Good Read Light	On
Beeper Volume	Medium
Backlight Off (battery power)	30 seconds
Backlight Off (external power)	1 minute
Backlight Level	High
Scan Button Remapping (handle trigger)	BRI
Scan Button Remapping (right scan button)	Scanner
Scan Button Remapping (left scan button)	Scanner

## **Appendix A – Specifications and Default Settings**

<b>Device Settings (continued)</b>	<b>Default Value</b>
Scan Button Remapping (middle scan button)	Scanner
Power Profiles	Standard
Power Button	Off when pressed
Device Off (battery power)	2 minutes
Display Off (battery power)	1 minute
Device Off (external power)	Disabled
Display Off (external power)	Disabled

## **GPS**

<b>Setting</b>	<b>Default Value</b>
Extended Ephemeris Data	Disable
Download Interval	Disable
Download Interval Start Time	1:00 AM
Download Interval Stop Time	3:00 AM
Push Interval	Disable
Push Interval Start Time	1:00 AM
Push Interval Stop Time	3:00 AM
Poll Period	Disable
Position Change	50 meters
Fix Interval	0
WAAS	Disable
Baud Rate	33600

## **Device Monitor**

<b>Setting</b>	<b>Default Value</b>
Poll Period	1 minute
Backup Battery Charge Remaining	10
Storage Load	90
Memory Load	90

## **Core Messaging Service**

<b>Setting</b>	<b>Default Value</b>
Keep Alive Ping Interval	30 seconds

***Appendix A – Specifications and Default Settings***



# B

## Keypads and Keystrokes

# Standard Characters

Use the following tables to learn how to enter standard and other available characters and functions with the keypad. If there is no sequence of keystrokes for a particular character or function, it is only available through the soft input panel (SIP), which can be accessed by tapping the keyboard icon on the touch screen.

## Alphanumeric Characters

Character	Numeric Keypad	QWERTY Keypad	Alphabetic Keypad
a	<b>2</b>	<b>A</b>	<b>A</b>
b	<b>2</b> <b>2</b>	<b>B</b>	<b>B</b>
c	<b>2</b> <b>2</b> <b>2</b>	<b>C</b>	<b>C</b>
d	<b>3</b>	<b>D</b>	<b>D</b>
e	<b>3</b> <b>3</b>	<b>E</b>	<b>E</b>
f	<b>3</b> <b>3</b> <b>3</b>	<b>F</b>	<b>F</b>
g	<b>4</b>	<b>G</b>	<b>G</b>
h	<b>4</b> <b>4</b>	<b>H</b>	<b>H</b>
i	<b>4</b> <b>4</b> <b>4</b>	<b>I</b>	<b>I</b>
j	<b>5</b>	<b>J</b>	<b>J</b>
k	<b>5</b> <b>5</b>	<b>K</b>	<b>K</b>
l	<b>5</b> <b>5</b> <b>5</b>	<b>L</b>	<b>L</b>
m	<b>6</b>	<b>M</b>	<b>M</b>
n	<b>6</b> <b>6</b>	<b>N</b>	<b>N</b>
o	<b>6</b> <b>6</b> <b>6</b>	<b>O</b>	<b>O</b>
p	<b>7</b>	<b>P</b>	<b>P</b>

**Alphanumeric Characters (continued)**

Character	Numeric Keypad	QWERTY Keypad	Alphabetic Keypad
q	7 7		
r	7 7 7		
s	7 7 7 7		
t	8		
u	8 8		
v	8 8 8		
w	9		
x	9 9		
y	9 9 9		
z	9 9 9 9		
A	1 2		
B	1 2 2		
C	1 2 2 2		
D	1 3		
E	1 3 3		
F	1 3 3 3		
G	1 4		
H	1 4 4		
I	1 4 4 4		
J	1 5		

Alphanumeric Characters (continued)

Character	Numeric Keypad	QWERTY Keypad	Alphabetic Keypad
K	1 5 5	K	K
L	1 5 5 5	L	L
M	1 6	M	M
N	1 6 6	N	N
O	1 6 6 6	O	O
P	1 7	P	P
Q	1 7 7	Q	Q
R	1 7 7 7	R	R
S	1 7 7 7 7	S	S
T	1 8	T	T
U	1 8 8	U	U
V	1 8 8 8	V	V
W	1 9	W	W
X	1 9 9	X	X
Y	1 9 9 9	Y	Y
Z	1 9 9 9 9	Z	Z
0	0		
1	1	Y	J
2	2	U	K
3	3	I	L

**Alphanumeric Characters (continued)**

Character	Numeric Keypad	QWERTY Keypad	Alphabetic Keypad
4			
5			
6			
7			
8			
9			

**Other Available Characters**

The next table lists both characters printed on the keypad overlays and hidden characters not printed on the overlays.

**Other Available Characters and Functions**

To Enter	Numeric Keypad	QWERTY Keypad	Alphabetic Keypad
^ (caret)	N/A	N/A	
@ (ampersand)	N/A		
& (and)	N/A		
* (asterisk)	N/A		
: (colon)	N/A		
, (comma)	N/A		
\$ (dollar)	N/A		
" (double quote)	N/A		
! (exclamation)	N/A		

**Other Available Characters and Functions (continued)**

To Enter	Numeric Keypad	QWERTY Keypad	Alphabetic Keypad
> (greater than)	N/A		
- (hyphen)			
( (left parentheses)	N/A		
< (less than)	N/A		
% (percent)	N/A		
. (period)			
+ (plus)			
# (pound)	N/A		
? (question mark)	N/A		
) (right parentheses)	N/A		
' (single quote)	N/A		
_ (underscore)	N/A		
BackTab			
CapsLock			
Enter			
Application Softkey 2			
ok			
Shift			
Application Softkey 1			
Space			

Characters not available from the keypads are:

- Left and right bracket ([ or ])
- Left and right curly bracket ({ or })
- Semicolon (;)
- Tilde (~)

Use the SIP to enter these characters.

## Language-Specific Characters

The next table lists the available language-specific characters, such as those using diacritical marks. The key sequences in this procedure assume that Caps Lock is not enabled and that the orange and green modifier keys are not locked when you start.



**Note:** These characters are not available on the CN4 numeric keypad.

### To type language-specific characters on the CN4e numeric keypad

- 1 Press to lock the green modifier key.
- 2 Type the parent character.
- 3 Press to cycle through the variant characters until you find the character you want. For more information, see the next table.
- 4 Press to unlock the green key.

### To type language-specific characters on the QWERTY and alphabetic keypads

- 1 Type the parent character.
- 2 Press to lock the orange modifier key.
- 3 On the alphabetic keypad, press to cycle through the variant characters until you find the character you want. For more information, see the next table.

On the QWERTY keypad, press to cycle through the variant characters until you find the character you want. For more information, see the next table.

4 Press  to unlock the orange key.

### Language-Specific Characters

Parent Character	Variant Characters								
a	à	á	â	ä	å	ã	ą	ă	æ
A	À	Á	Â	Ä	Å	Ã	Ą	Ă	Æ
c	ç	ć	č	©					
C	Ç	Ć	Č	©					
d	đ								
D	Đ								
e	è	é	ê	ë	ę				
E	È	É	Ê	Ë	Ę				
i	ì	í	î	ï					
I	Ì	Í	Î	Ï					
l	ł								
L	Ł								
n	ñ								
N	Ñ								
o	ò	ó	ô	õ	ö	ő	ø	œ	
O	Ò	Ó	Ô	Õ	Ö	Ő	Ø	Œ	
p	ƀ	Ɔ							
P	Ɔ	ƀ							
r	®								
R	®								
s	ș	š	ß						
S	Ș	Š	ß						
t	ţ								
T	Ț								
u	ù	ú	û	ü	ů				
U	Ù	Ú	Û	Ü	Ů				
y	ý								
Y	Ý								
z	ž	ž							
Z	Ž	Ž							





# Index

**Numerics**

- 802.1x security
  - with Funk 63
  - with Microsoft 67

**A**

- AA15 audio adapter, described 109
- AA16 Ethernet adapter, described 109
- AA17 RS-232/DEX adapter, described 109
- AA18 USB adapter, described 109
- AC14 quad battery charger, described 109
- accessories, described 109
  - accessory
    - audio adapter 109
    - charge-only multidock 109
    - Ethernet adapter 109
    - magnetic card reader 110
    - multidock 109
    - quad battery charger 109
    - RS-232/DEX adapter 109
    - scan handle 110
    - single dock 109
    - USB adapter 109
    - vehicle dock 110
    - vehicle power adapter 109
- Activation Wizard, starting 47
- ActiveSync, using to install applications 74
- AD10 single dock, described 109
- AD11 multidock, described 109
- AD12 charge-only multidock, described 109
- AE11 vehicle power adapter, described 109
- aligning screen 21
- alphabetic keypad
  - entering characters 13
  - illustrated 12
  - keypresses, listed 118–124
- amber battery LED, described 6
- applications
  - developing 72
    - packaging 72
    - target location on CN4 72
  - Enhanced Mobile Document Imaging 32
  - iConnect 58
  - Image Capture, integrating 76

applications (*continued*)

- Image Capture, using 29
  - installing 73
    - ActiveSync 74
    - FTP server 75
    - miniSD card 74
  - launching automatically 75
  - troubleshooting 98
  - AR1 magnetic card reader, described 110
  - area imager. *See* imager
  - audio adapter, described 109
  - audio device, Bluetooth, connecting to 57
  - audio features 15
    - cell phone mike and speaker 15
    - front speaker 16
    - rear speaker volume 17
  - authentication
    - setting 65–68
    - troubleshooting 91
  - AutoRun 75
  - AV6 vehicle dock, described 110
  - AV9 vehicle dock, described 110
- B**
- backlight, configuring 22
  - bar codes
    - configuring the CN4 to read 48
    - enabled by default 27
    - reading 25
  - battery
    - changing 4
    - charging 4
    - description 3–7
    - icons 6
    - icons, understanding 20
    - installing 4
    - internal backup 4
    - maximizing life 8
    - specifications 103
    - status LED 4, 6
    - status, checking 7
    - troubleshooting status LED 90
  - beeps
    - three low, troubleshooting 89
    - volume, changing 17
  - blue LED, described 23
  - Bluetooth
    - audio device, connecting to 57
    - configuring 54

- Bluetooth (*continued*)
  - printer, connecting to 56
  - QD ID 102
  - scanner, connecting to 55
  - Wireless Printing enabler 56
  - Wireless Scanning enabler 55
- Bluetooth Audio enabler 57
- booting the CN4 97
  - clean 99
  - cold 98
  - warm 98
- button, power 15
- C**
- calibrating screen 21
- calling product support 88
- camera 35
  - cleaning window 100
  - configuring 36
- capacitor, super, as backup power 4
- card, miniSD, using to install
  - applications 74
- carriers, supported 46
- CDMA
  - activation values table 47
  - carriers, supported 46
  - MSID 47
  - MSL 47
  - phone, activating 47
- cellular phone, using CN4 as 15, 46
  - CDMA, activating 46
  - GSM/EDGE, activating 48
  - making a call 48
  - mike and speaker, illustrated 16
  - power management profiles,
    - described 10
  - turning phone on and off 48
  - vibrate, enabling 18
- certificates, loading 68
- characters, typing with keypad 13
  - alphabetic, list of 118
  - hidden characters, list of 121
  - language-specific 123
  - punctuation, list of 121
  - special characters, list of 121
  - unsupported 123
- charge-only multidock, described 109
- clean boot, performing 99
- cleaning computer 100
- CN4
  - described 2
  - keypads, illustrated 12
  - Windows Mobile keys 14
  - See also* CN4 series computers.
- CN4 series computers
  - accessories 109
  - applications, developing and installing 72–76
  - audio 15
  - backlight 22
  - Bluetooth 54–57
  - camera 35
  - cleaning 100
  - communications, network 52–59
  - configuring settings 48
  - default settings 110–115
  - described 2
  - documents, capturing 32
  - features 3
  - GPS 39
  - imager 24
  - images, capturing 29
  - keypads, using 12
  - LEDs, understanding 23
  - miniSD card 37
  - phone 46–48
  - power management 8
  - reading bar codes 25
  - resetting 97
  - screen 18
  - security, wireless 59–70
  - signatures, capturing 32
  - SIM card 37
  - SmartSystems Foundation 44
  - specifications 102–104
  - system software 82
  - troubleshooting 89–93
  - upgrading 82
- CN4e
  - described 2
  - keypads, illustrated 12
  - scan button locations 26
  - Windows Mobile keys 14
  - See also* CN4 series computers.
- CN4NI
  - described 2

- cold boot, performing 98
- color-coded keys 13
- communications
  - 802.11, configuring 53
  - available protocols 102
  - Bluetooth, configuring 54–57
  - configuring CN4 for network 52
  - default settings 113
  - Ethernet, configuring 53
  - phone, activating 46
  - security, wireless 59
  - serial 57
  - troubleshooting wireless network 94
  - USB 57
- configuration commands, troubleshooting 89
- configuration number, finding 88
- configuring the CN4 48
  - 802.11 communications 53
  - applications, auto-launching 75
  - backlight 22
  - Bluetooth 54
  - cell phone 46
  - certificates, loading 68
  - Ethernet 53
  - GPS 39
  - Intermec Settings 48–52
  - network communications 52
  - phone 46
  - power management profiles, choosing 9
  - power timeout values 10
  - security, wireless 59
  - SmartSystems console 49
  - vibrate mode 18
  - volume, for cell phone 16
  - volume, for general audio 17
  - WAN 46–48
- console 49
- core messaging service settings, default 115
- D**
- data collection settings, default 110
- data rates 103
- decode security settings, default 112
- default settings 110–115
  - communications 113
  - core messaging service 115
  - default settings (*continued*) 110–115
    - data collection 110
    - decode security 112
    - device 113
    - device monitor 115
    - GPS 115
    - imager 112
    - symbology 110
    - symbology option 112
    - virtual wedge 112
  - device monitor settings, default 115
  - device settings, default 113
  - DEX adapter, described 109
  - diacritical marks, typing 123
  - diagnostics, for troubleshooting 99
  - dimensions, physical 102
  - display. See screen
  - downloads for CN4 42
  - drop specification 103
  - dust and rain resistance 103
- E**
- EA11 area imager
  - reading distance, minimum 108
  - reading distance, typical 107
- EA21 area imager
  - reading distance, minimum 106
  - reading distance, typical 105
- electrical specifications 103
- Electronic Serial Number (ESN), locating 46
- eMDI. See Enhanced Mobile Document Imaging
- Enhanced Mobile Document Imaging (eMDI) application 32
- environmental specifications 103
- Ethernet adapter, described 109
- extended ephemeris 39, 41
- F**
- front speaker, adjusting volume 16
- FTP server, using to install applications 75
- Funk security
  - 802.1x 63
  - described 60
  - LEAP 64
  - profile, choosing 61
  - WEP 64
  - WPA 61

**G**

- Good Read LED
  - described 23
  - troubleshooting 93
- GPS
  - configuring 39
  - default settings 115
  - extended ephemeris 39, 41
  - GPSID, overview 39
- green battery LED, described 6
- green key, using 13
- green status LED, described 23
- GSM/EDGE activation 48

**H**

- hardware specifications 102
- humidity specification 103

**I**

- iConnect application
  - described 58
  - enabling FTP server 75
- icons
  - battery 6
  - understanding 20
- IDL (Intermec Developer Library)
  - 72
- iGPS settings 41
- Image Capture application 29
  - using in your application 76
  - XML example 80
  - XML file 77
- imager 24
  - bar codes, reading 25
  - capturing images 29
  - cleaning window 100
  - default settings 112
  - documents, capturing 32
  - EA11 reading distances 107, 108
  - EA21 reading distances 105, 106
  - Enhanced Mobile Document
    - Imaging application 32
  - Image Capture application 29
  - improving performance 28
  - ink capture 32
  - predefined mode, choosing 28
  - reading distance, minimum 106
  - reading distance, typical 105
  - scan button locations, CN4 25
  - scan button locations, CN4e 26
  - signature capture 32

- imaging options 102
- ink capture, described 32
- installing
  - applications 73
  - battery 4
  - miniSD card 37
  - SIM card 37
- InstallSelect, using to free up
  - memory 80
- Intermec
  - Product Support, contacting 88
  - Resource Kits, described 72
  - value-add functionality,
    - described 82
- Intermec Developer Library (IDL)
  - 72
- Intermec Settings
  - described 48
  - menu items, hiding 52
  - restoring menu items 52
  - SmartSystems console, opening
    - from 49
    - using on CN4 50
- Internet Explorer, using to find OS
  - version 89

**K**

- keypads 102
  - illustrated 12
  - keypresses, listed 118–124
  - language-specific characters 123
  - troubleshooting keys 89
  - using 12
    - using color-coded keys 13
- keypresses, listed 118–124
- Knowledge Central website 88

**L**

- launching applications
  - automatically 75
- LCD. See screen.
- LEAP security, configuring 64
- LEDs
  - battery 6
  - status 23
- locked computer, troubleshooting
  - 90
- lower power mode 15

**M**

- magnetic card reader, described
  - 110

- Master Subsidy Lock (MSL) 47
- memory 102
  - freeing up virtual for applications 80
  - installing applications in 72
- microprocessor 102
- Microsoft security
  - 802.1x 67
  - choosing 65
  - static WEP 68
  - when to use 60
  - WPA 65
  - WPA-802.1x 65
  - WPA-PSK 66
- miniSD card
  - installing 37
  - specification 102
  - using to install applications 74
  - using to upgrade computer 85
- Mobile Country Code (MCC) 47
- Mobile Directory Number (MDN) 47
- Mobile Network Code (MNC) 47
- Mobile Station Identification Number (MSIN) 47
- Mobile Station Identifier (MSID) 47
- multidock, described 109
- My Pictures folder 35

**N**

- network connection icons, understanding 20
- Network ID (NID) 47
- Notification LED, described 23
- numeric keypad
  - entering letters and symbols 14
  - illustrated 12
  - keypresses, listed 118–124

**O**

- Object Store, storing applications 72
- operating system
  - finding version 89
  - how to upgrade 82
  - specification 102
- operating temperature 103
- orange key, using 13

- orange LED, described 23

**P**

- persistent storage, how to upgrade 82
- phone
  - CDMA, activating 46
  - configuring 46
  - GSM/EDGE, activating 48
  - making a call 48
  - mike and speaker, illustrated 16
  - power management profiles, described 10
  - turning on and off 48
  - using 15
  - vibrate, enabling 18
- physical specifications 102
- Pictures & Videos, using to take pictures 36
- pictures, storage location 35
- power
  - backlight settings 22
  - battery 3–11
  - battery life, maximizing 8
  - button 15
  - management profiles
    - choosing 9
    - described 10
  - managing 8
  - timeout values, customizing 10
- Power application, using to check battery status 7
- Power button 15
- power specifications 103
- predefined modes, for imager 28
- printer, Bluetooth, connecting to 56
- problems, troubleshooting 89–93
  - product support
    - calling 88
    - Knowledge Central website 88
  - product support, calling 88

**Q**

- quad battery charger, described 109
- QWERTY keypad
  - entering characters 13
  - illustrated 12
  - keypresses, listed 118–124

- R**
- radio
    - certifications 103
    - power output 103
  - radios
    - 802.11 53
    - Bluetooth 54–57
    - WAN 46–48
    - wireless security 59–68
  - rain and dust resistance 103
  - reading distances
    - EA11 107, 108
    - EA21 105, 106
  - Ready-to-Work indicator LED,
    - described 23
  - recharge temperature 103
  - recharge times 103
  - red battery LED, described 6
  - regulatory approvals 104
  - reset, performing 97
  - resource kits, for application
    - development 72
  - RS-232 adapter, described 109
- S**
- scan button locations, illustrated
    - CN4 25
    - CN4e 26
  - scan handle, described 110
  - scanner
    - Bluetooth, connecting to 55
    - default settings 112
    - troubleshooting 92–93
  - Scan-to-Connect 45
  - screen 18
    - aligning 21
    - cleaning 100
    - icons, understanding 20
    - no response, troubleshooting 90
    - specifications 103
    - stylus, using 19
    - Windows Mobile Today 18
  - Screen Off mode 22
  - security 103
    - security, wireless 59
      - 802.1x with Funk 63
      - 802.1x with Microsoft 67
      - certificates, loading 68
      - LEAP with Funk 64
      - static WEP
        - with Funk 64
      - security, wireless (*continued*) 59
        - WEP with Microsoft 68
        - WPA with Funk 61
        - WPA with Microsoft 65
    - Service Programming Code (SPC) 47
    - signature capture, described 32
    - SIM card, installing 37
    - single dock, described 109
    - SmartSystems Foundation 44
      - applications, installing 73
      - AutoDeploy 45
      - Intermec Settings, using from console 49
      - Scan-to-Connect 45
      - upgrading CN4 84
      - where to download 45
    - SmartSystems Platform Bundle
      - files, described 82
      - removing features to free up memory 80
      - upgrading with miniSD card 85
    - specifications 102–104
      - communications 102
      - electrical 103
      - environmental 103
      - hardware 102
      - physical 102
      - power 103
    - SSPB. *See* SmartSystems Platform Bundle
    - Standard 118
    - static WEP
      - with Funk 64
      - with Microsoft 68
    - storage temperature 103
    - stylus, using 19
    - super capacitory, as backup power 4
    - Suspend mode 15
    - symbolgies
      - configuring the CN4 to read 48
      - default settings 110
      - enabled by default 27
    - symbology options, default 112
    - System ID (SID) 47

**T**

    - temperatures 103
    - terminal emulation,
      - troubleshooting 91

- touch screen, aligning 21
  - troubleshooting 89–93
    - 802.11 connectivity 90
    - 802.11 network status 94
    - 802.1x security 91
    - authentication 91
    - bar codes, reading 92
    - configuration 89
    - imager 28
    - operation 90
  - turning the CN4 on and off 15
- U**
- upgrade files, downloading 83
  - upgrading
    - operating system, overview 82
    - persistent storage, overview 82
    - using a miniSD card 85
    - with SmartSystems Foundation 84
  - USB adapter, described 109
- V**
- vehicle dock, described 110
  - vehicle power adapter, described 109
  - vibrate, enabling 18
  - virtual memory, freeing up 80
  - virtual wedge settings, default 112
  - volume
    - front speaker, adjusting 16
    - icon, understanding 20
    - rear speaker, adjusting 17
- W**
- WAN, configuring 46–48
    - CDMA 46
    - GSM/EDGE 48
  - warm boot, performing 98
  - WEP, static 64
  - Windows Mobile keys 14
  - Windows Mobile Today screen, illustrated 18
  - wireless
    - connectivity, troubleshooting 90–91
    - security 59–70
  - wireless LAN specifications 103
  - Wireless Printing enabler, for Bluetooth 56
  - Wireless Scanning enabler 55
  - wireless security 59
    - 802.1x with Funk 63
    - certificates, loading 68
    - LEAP with Funk 64
    - static WEP with Funk 64
    - troubleshooting 91
    - WPA with Funk, configuring 61
  - WPA security
    - with Funk 61
    - with Microsoft 65
  - WPA-PSK security
    - with Funk 61
    - with Microsoft 66
  - www.intermec.com
    - downloads for CN4 42, 83
    - Intermec Developer Library 42, 72
    - Knowledge Central 88
    - manuals, downloading x, xi
    - Product Support 88
    - SmartSystems Foundation 45
    - warranty information ix
- X**
- XML, for Image Capture application 77, 80





Worldwide Headquarters  
6001 36th Avenue West  
Everett, Washington 98203  
U.S.A.

tel 425.348.2600

fax 425.355.9551

[www.intermec.com](http://www.intermec.com)

© 2011 Intermec Technologies  
Corporation. All rights reserved.

**CN4 Mobile Computer User's Manual**



P/N 935-029-003